

Charge Coupled Devices in Astronomy

Philippe Feautrier

Observatoire de Grenoble, France

<http://www-laog.obs.ujf-grenoble.fr/>

Philippe.Feautrier@obs.ujf-grenoble.fr

References: 2 “bibles”

- **Courses**

Main part of this course extracted from Simon Tulloch webpage (Isaac Newton Group of Telescope, La Palma, Spain):

http://www.ing.iac.es/~smt/CCD_Primer/CCD_Primer.htm

- **Reference book on CCDs:**

Scientific Charge-Coupled Devices, by James R. Janesick, SPIE Press, ISBN 0-8194-3698-4, SPIE Order No. PM83

CCD_Primer - Mozilla Firefox

File Edit View Go Bookmarks Tools Help

http://www.ing.iac.es/~smt/CCD_Primer/CCD_Primer.htm Go [simon.tulloch@ing](#)

Hotmail Personnaliser les liens Windows Media Windows

Isaac Newton Group of Telescopes

Introduction to CCDs

RAIN (PHOTONS) VERTICAL CONVEYOR BELTS (CCD COLUMNS)

BUCKETS (PIXELS) MEASURING CYLINDER (OUTPUT AMPLIFIER)

HORIZONTAL CONVEYOR BELT (SERIAL REGISTER)

This page contains four downloadable Powerpoint presentations, of about 50 slides each, that provide a good introduction to CCDs

Activity 1: Introduction to CCDs	Activity 2: Use of CCD Cameras	Activity 3: Advanced CCD Telescopes
Download Section 1 (1.1MB)	Download Section 2 (0.9MB)	Download Section 3 (2.3MB)

Done

Content of this course

- Introduction to CCDs: basic principle of CCD imaging
- Use of CCD cameras: practical considerations on building and using CCD cameras
- Advanced CCD techniques: Fast/low devices, CDS, noise sources, photon transfer curve and noise measurement, Deep depletion devices
- Low Light Level CCDs

Chapter 1 : Introduction to CCDs.

In this chapter, the basic principles of CCD Imaging is explained.

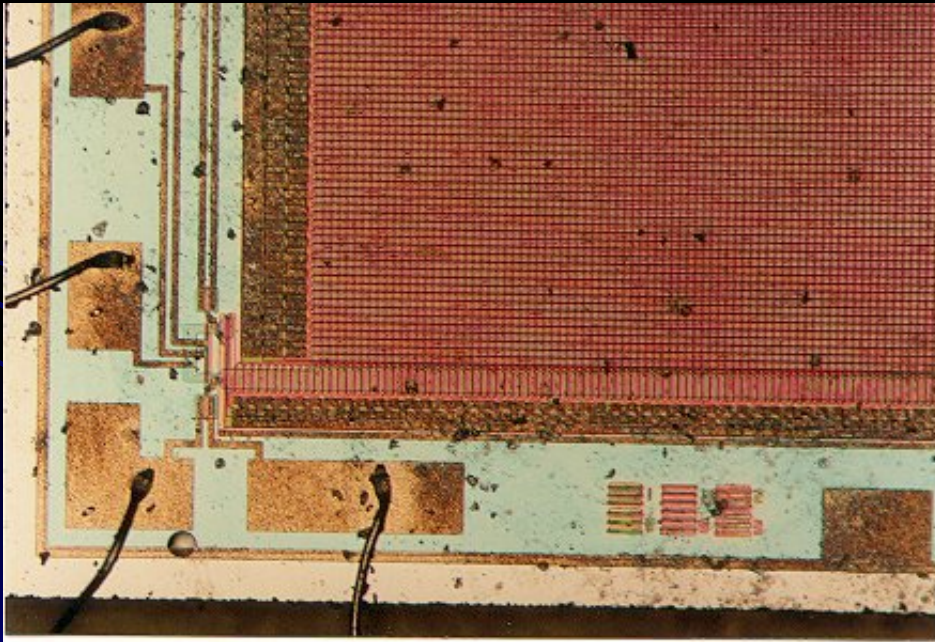

What is a CCD ?

Charge Coupled Devices (CCDs) were invented October 19, 1969, by Boyle and Smith and originally found application as memory devices. Their light sensitive properties were quickly exploited for imaging applications and they produced a major revolution in Astronomy. They improved the light gathering power of telescopes by almost two orders of magnitude. Nowadays an amateur astronomer with a CCD camera and a 15 cm telescope can collect as much light as an astronomer of the 1960s equipped with a photographic plate and a 1m telescope.

CCDs work by converting light into a pattern of electronic charge in a silicon chip. This pattern of charge is converted into a video waveform, digitized and stored as an image file on a computer.

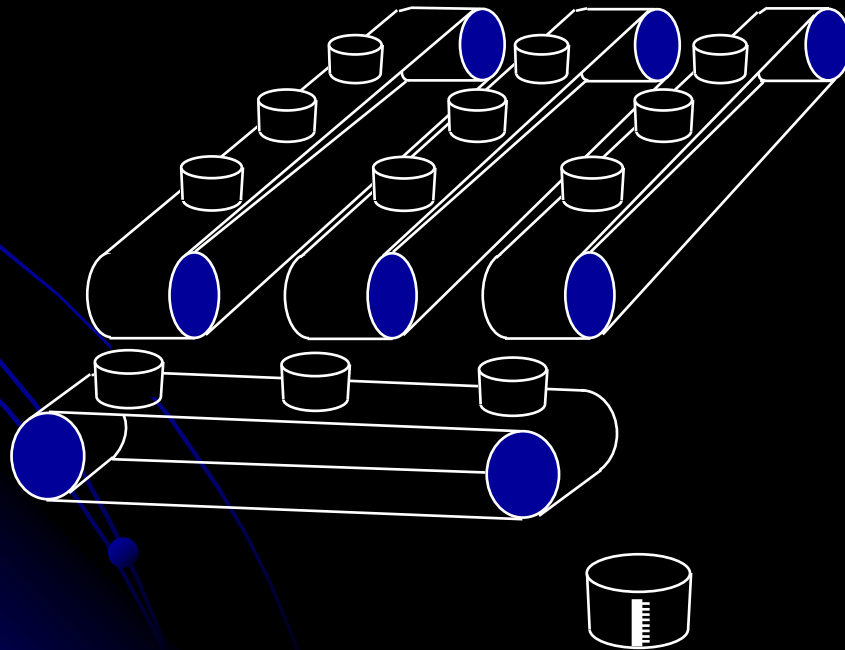

Photoelectric Effect.

The effect is fundamental to the operation of a CCD. Atoms in a silicon crystal have electrons arranged in discrete energy bands. The lower energy band is called the Valence Band, the upper band is the Conduction Band. Most of the electrons occupy the Valence band but can be excited into the conduction band by heating or by the absorption of a photon. The energy required for this transition is 1.26 electron volts. Once in this conduction band the electron is free to move about in the lattice of the silicon crystal. It leaves behind a 'hole' in the valence band which acts like a positively charged carrier. In the absence of an external electric field the hole and electron will quickly re-combine and be lost. In a CCD an electric field is introduced to sweep these charge carriers apart and prevent recombination.

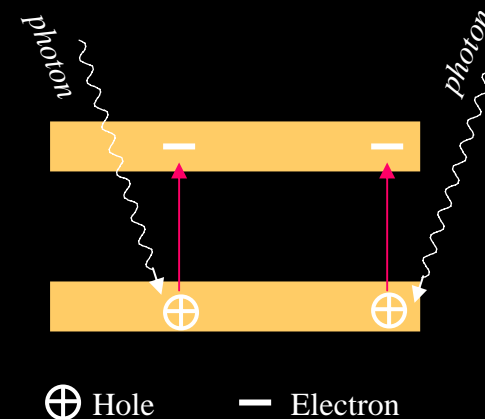
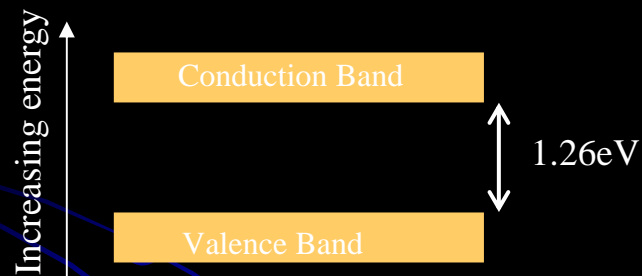

Thermally generated electrons are indistinguishable from photo-generated electrons. They constitute a noise source known as 'Dark Current' and it is important that CCDs are kept cold to reduce their number.

1.26eV corresponds to the energy of light with a wavelength of $1\mu\text{m}$. Beyond this wavelength silicon becomes transparent and CCDs constructed from silicon become insensitive.

CCD Analogy

A common analogy for the operation of a CCD is as follows:

An number of buckets (**Pixels**) are distributed across a field (**Focal Plane of a telescope**) in a square array. The buckets are placed on top of a series of parallel conveyor belts and collect rain fall (**Photons**) across the field. The conveyor belts are initially stationary, while the rain slowly fills the buckets (**During the course of the exposure**). Once the rain stops (**The camera shutter closes**) the conveyor belts start turning and transfer the buckets of rain , one by one , to a measuring cylinder (**Electronic Amplifier**) at the corner of the field (**at the corner of the CCD**)

The animation in the following slides demonstrates how the conveyor belts work.

CCD Analogy

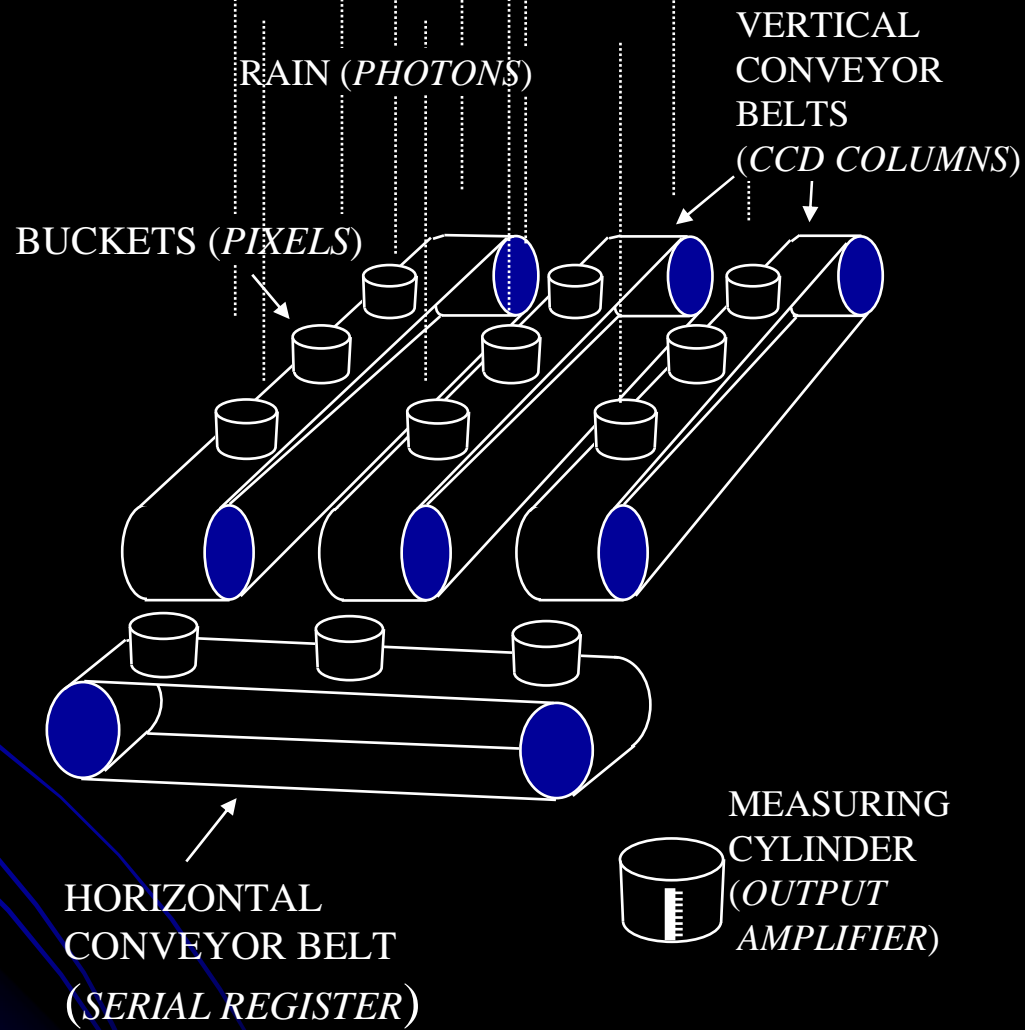

Exposure finished, buckets now contain samples of rain.

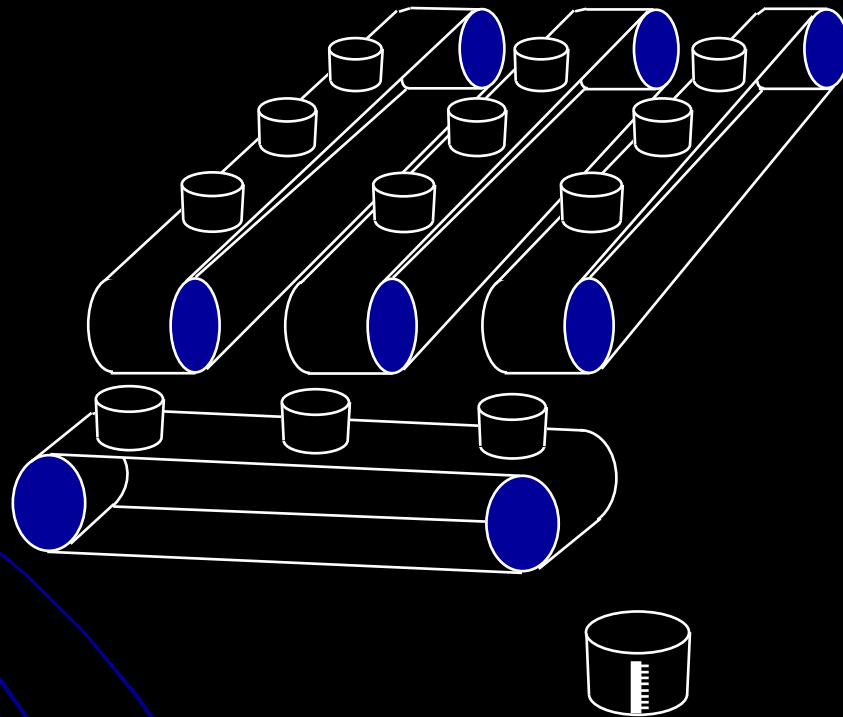

Conveyor belt starts turning and transfers buckets. Rain collected on the vertical conveyor is tipped into buckets on the horizontal conveyor.

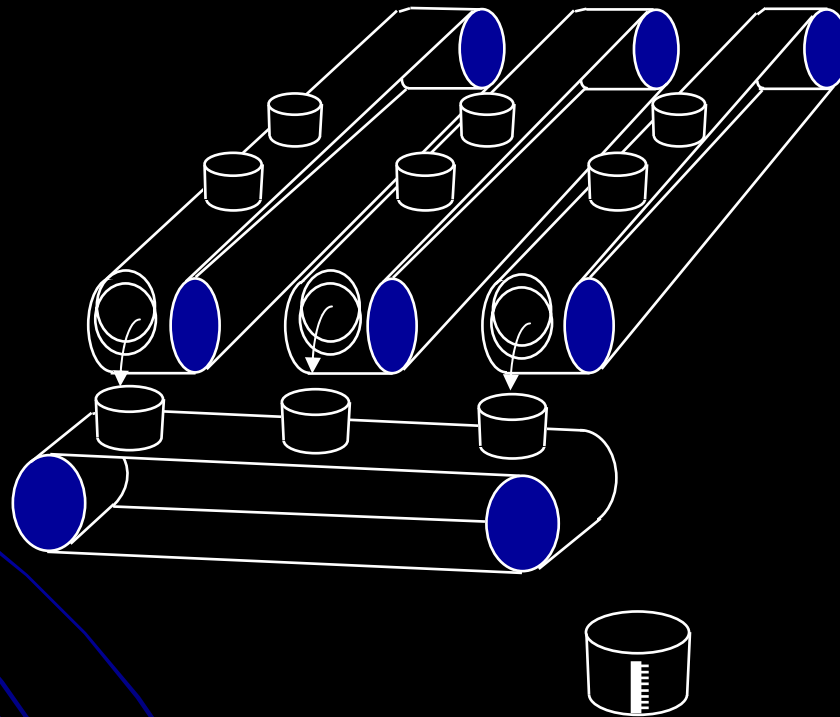

Vertical conveyor stops. Horizontal conveyor starts up and tips each bucket in turn into the measuring cylinder .

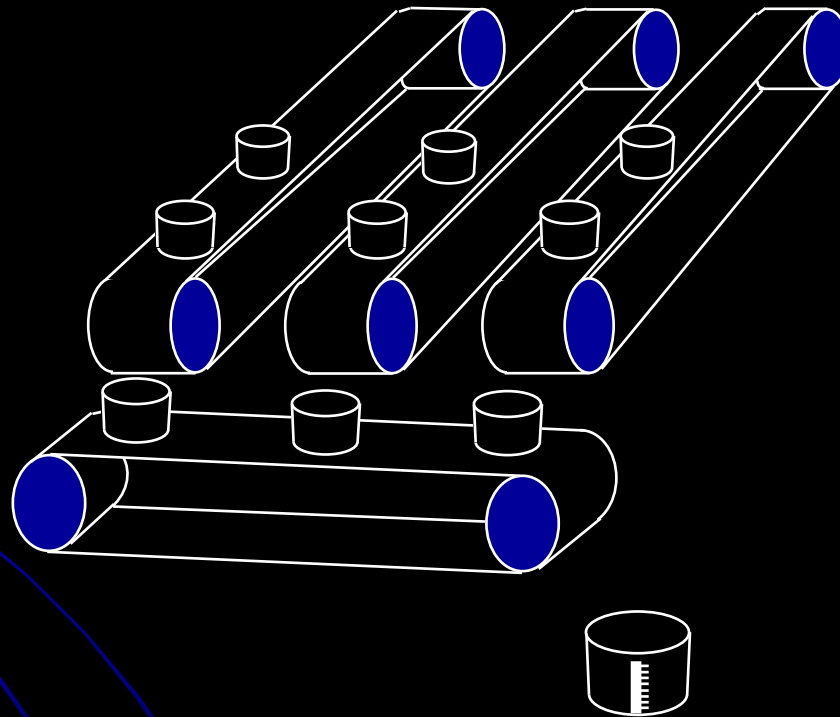

After each bucket has been measured, the measuring cylinder is emptied, ready for the next bucket load.

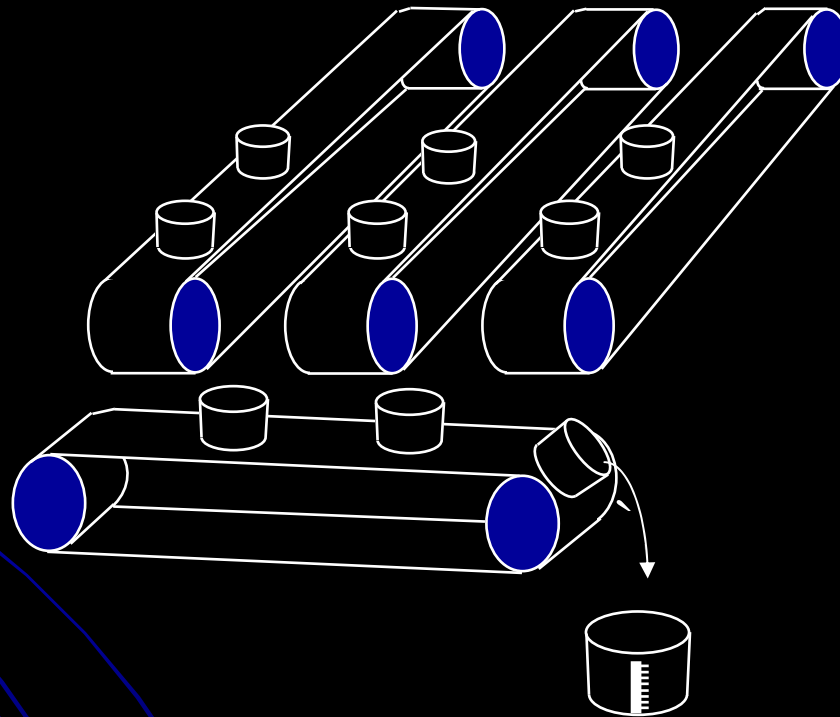

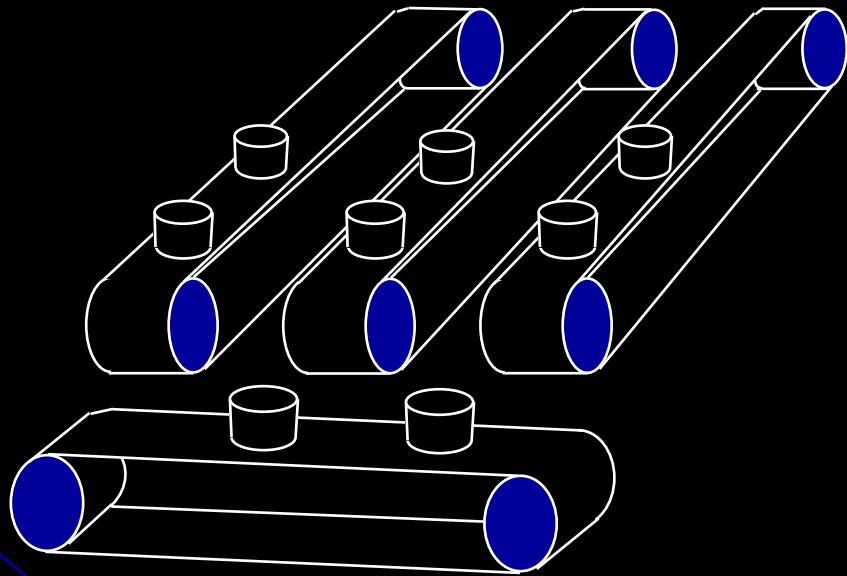

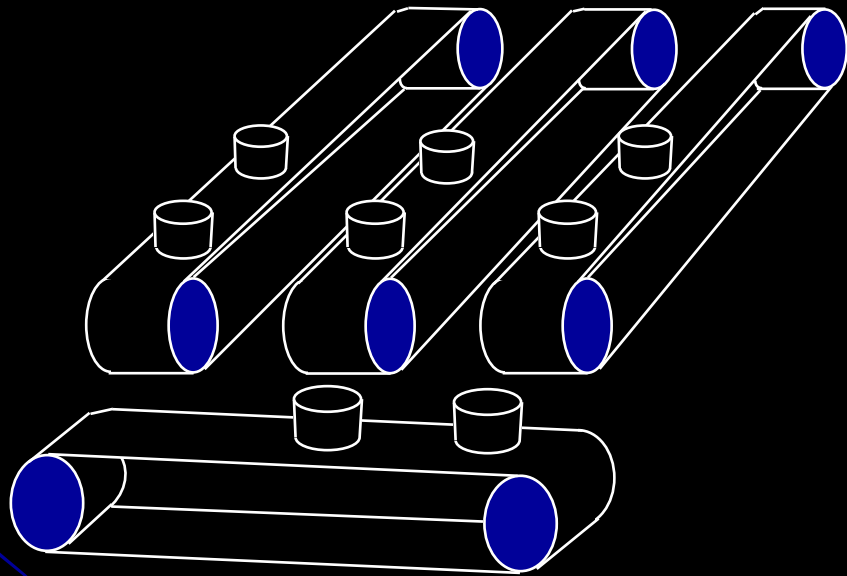

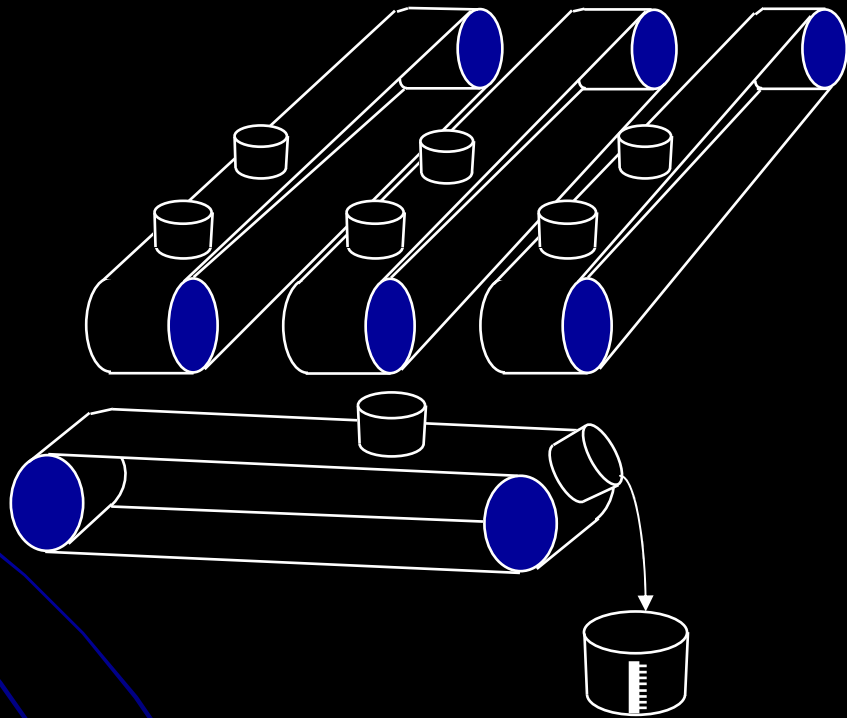

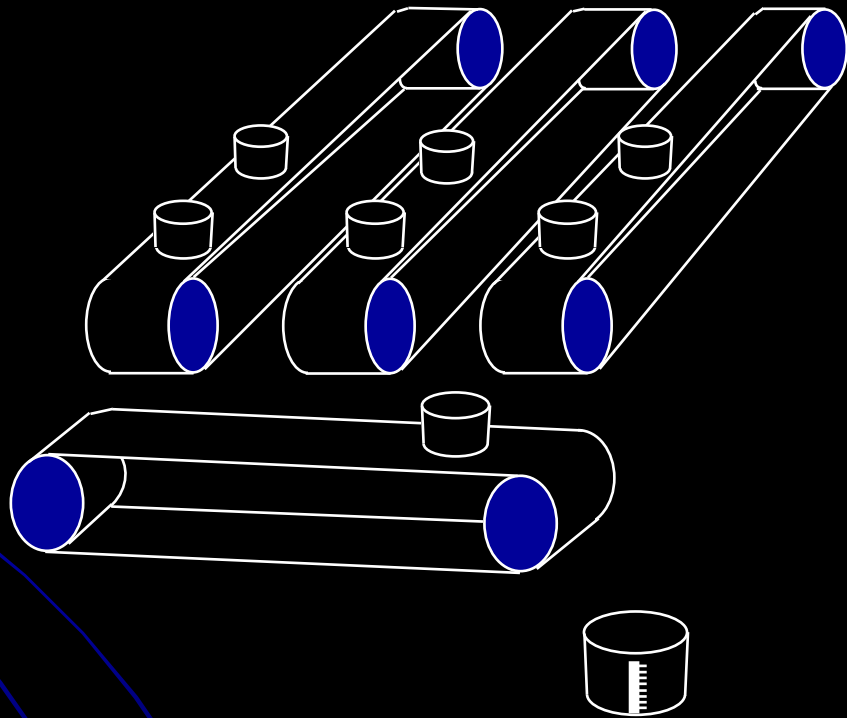

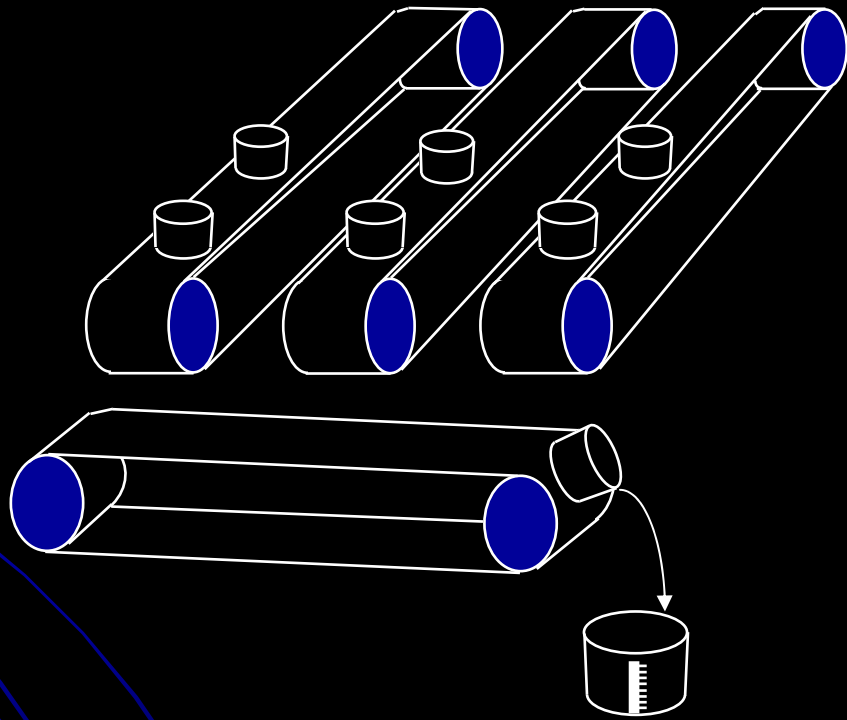

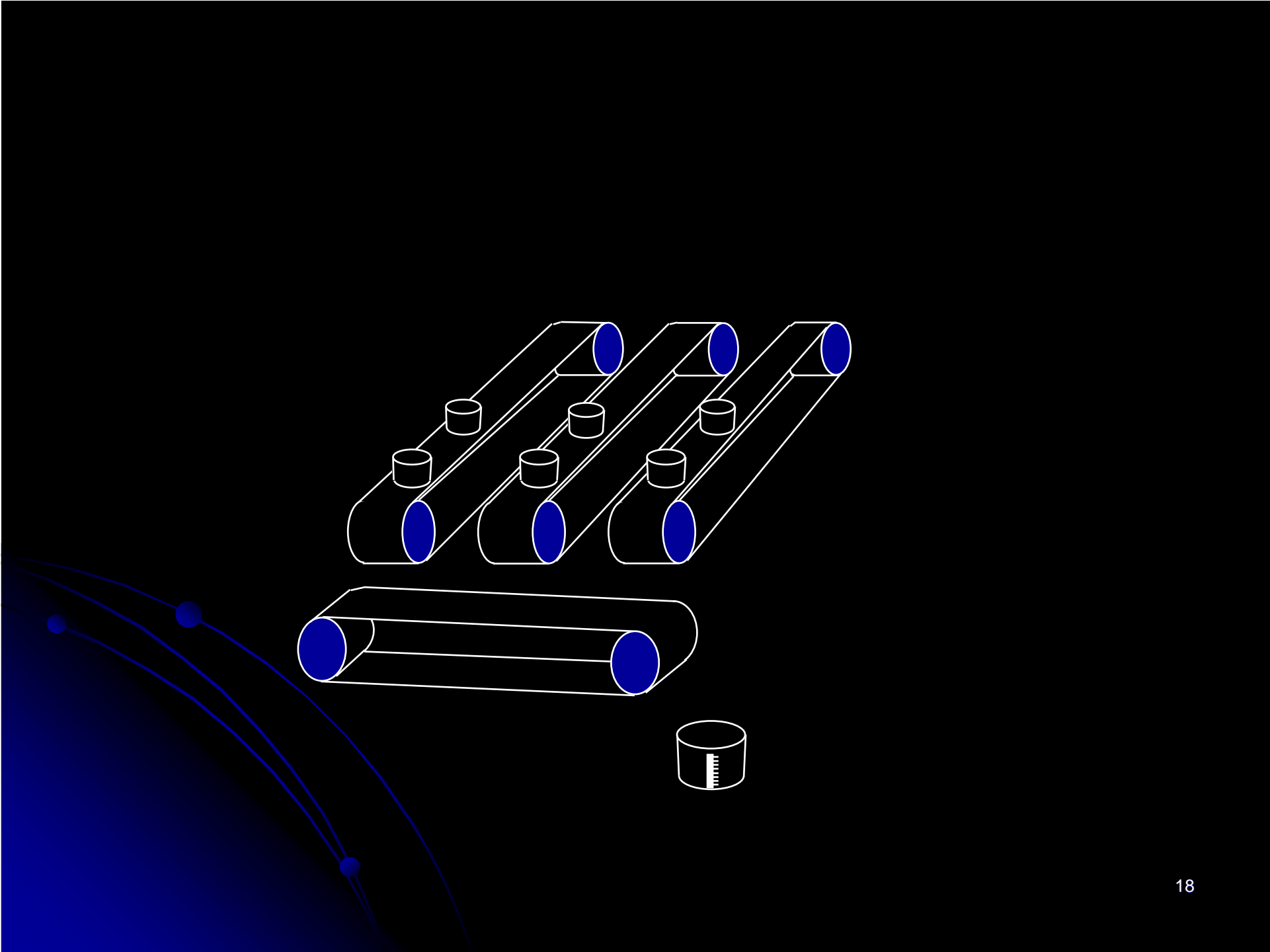

A new set of empty buckets is set up on the horizontal conveyor and the process is repeated.

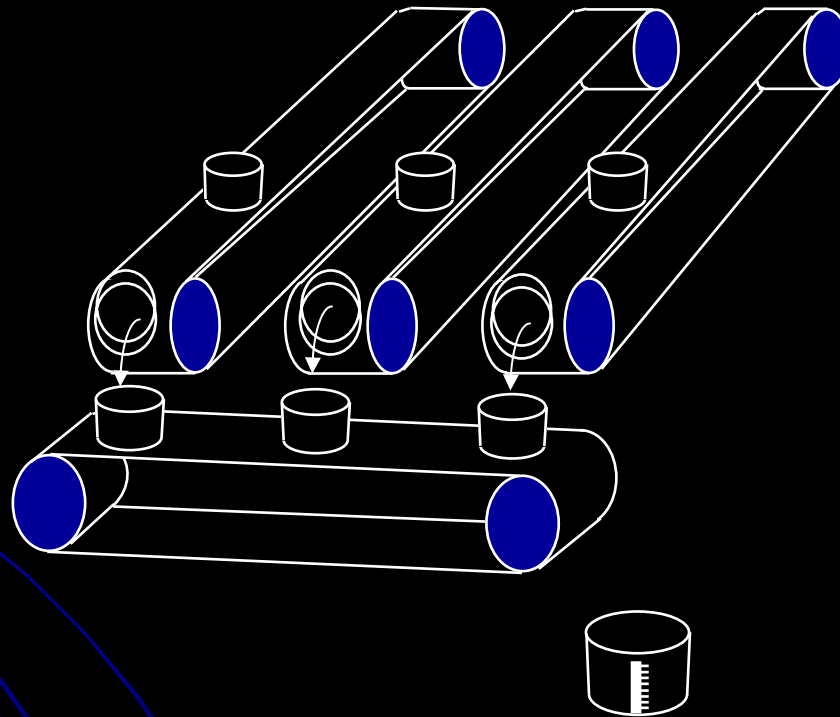

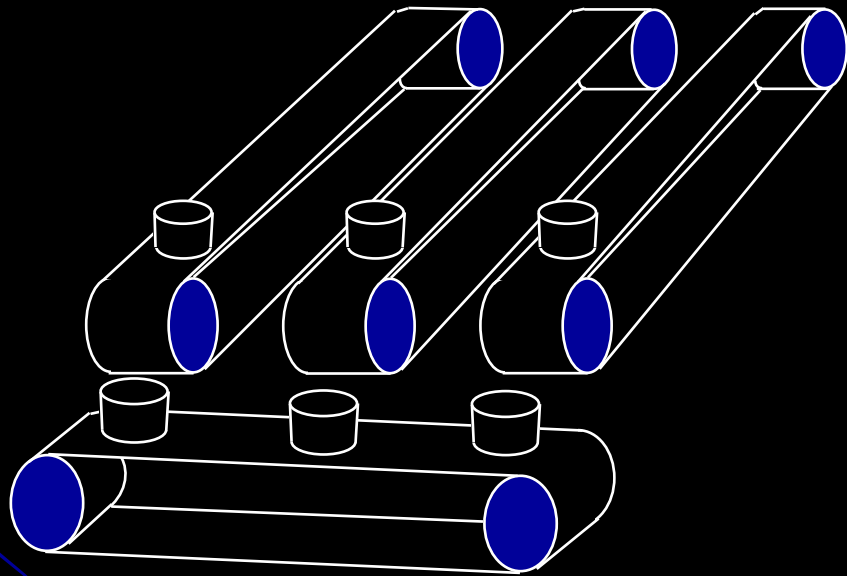

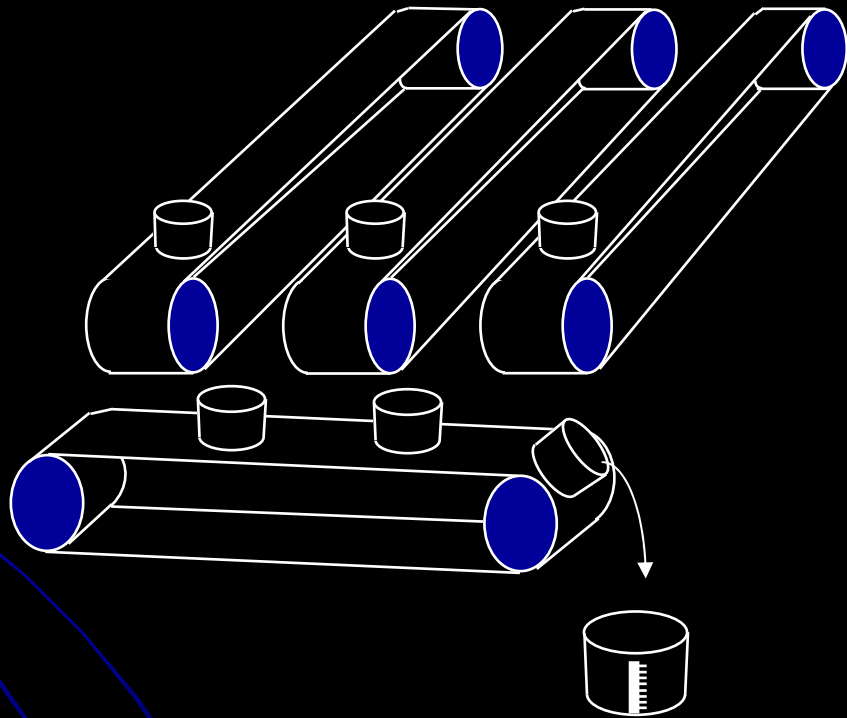

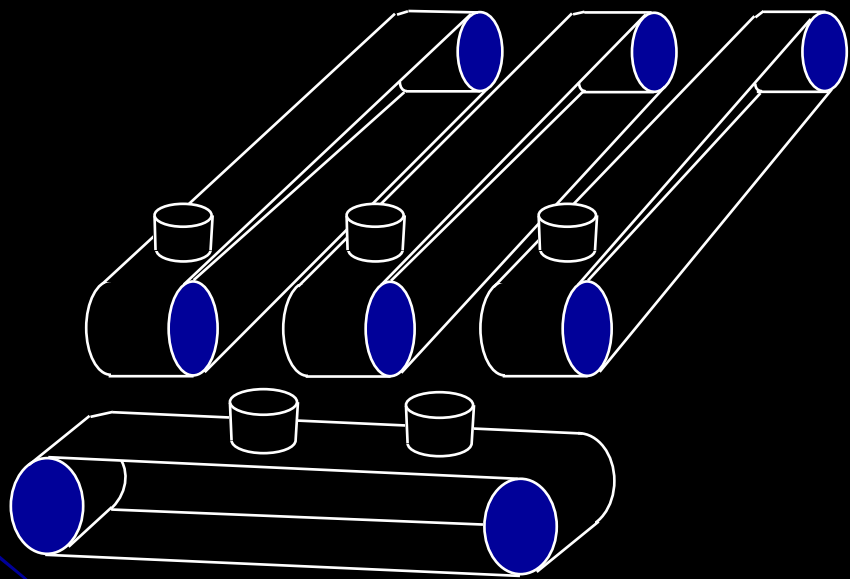

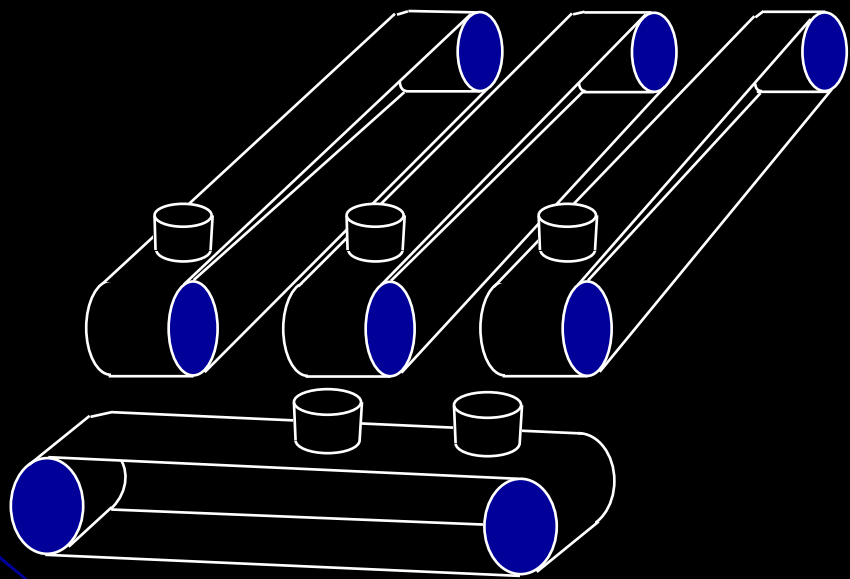

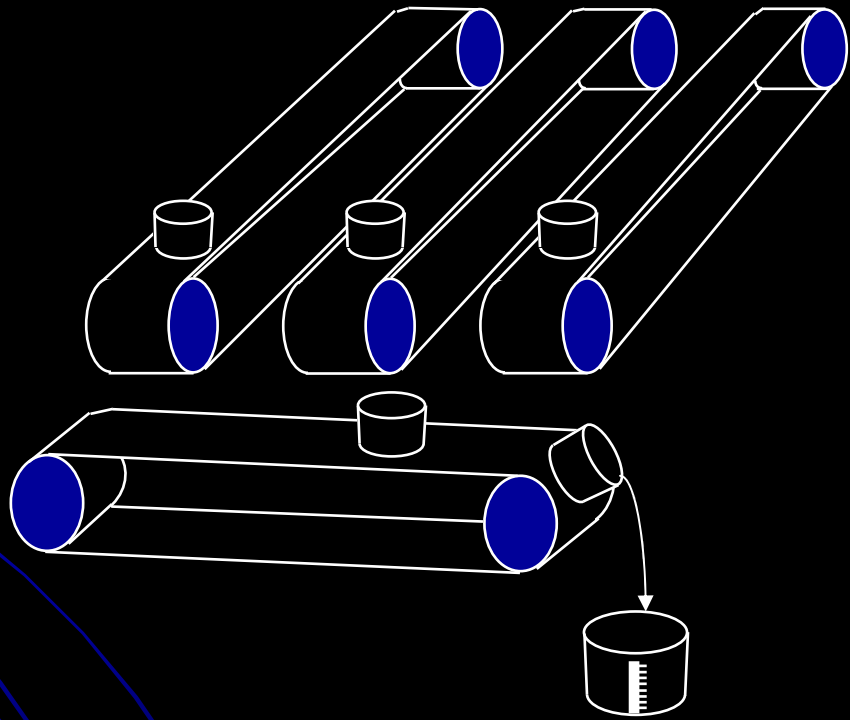

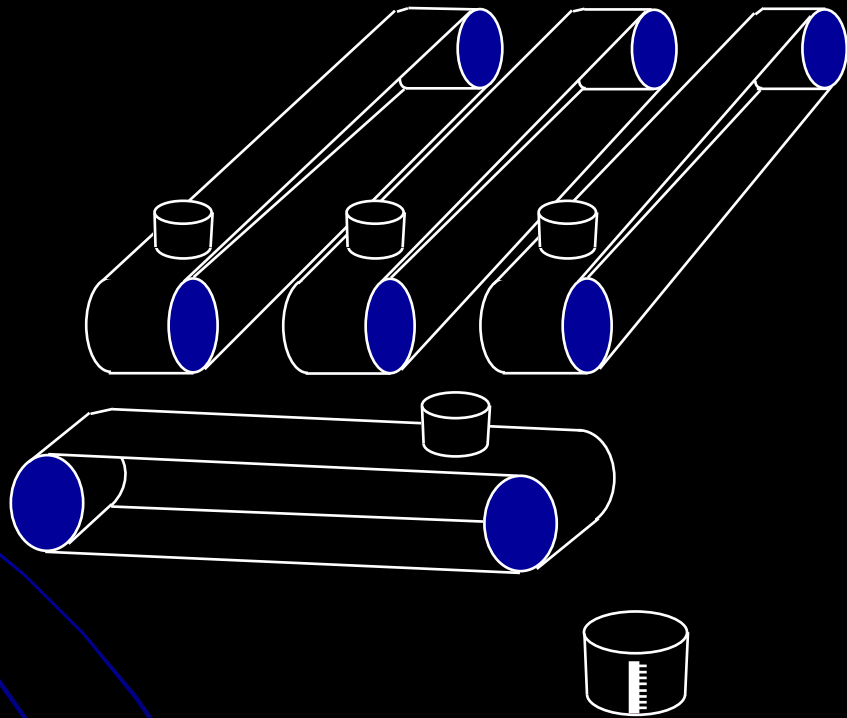

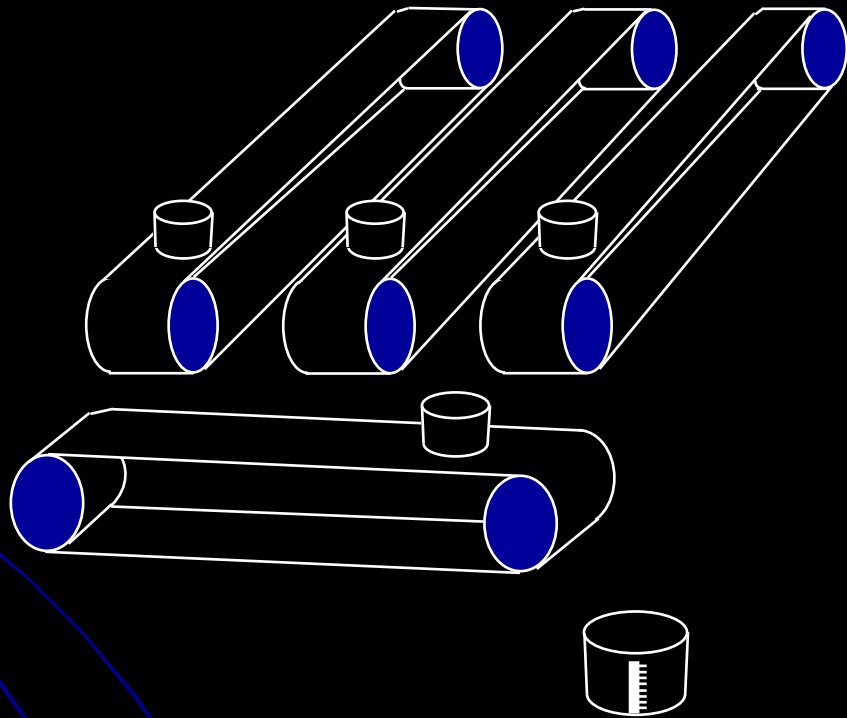

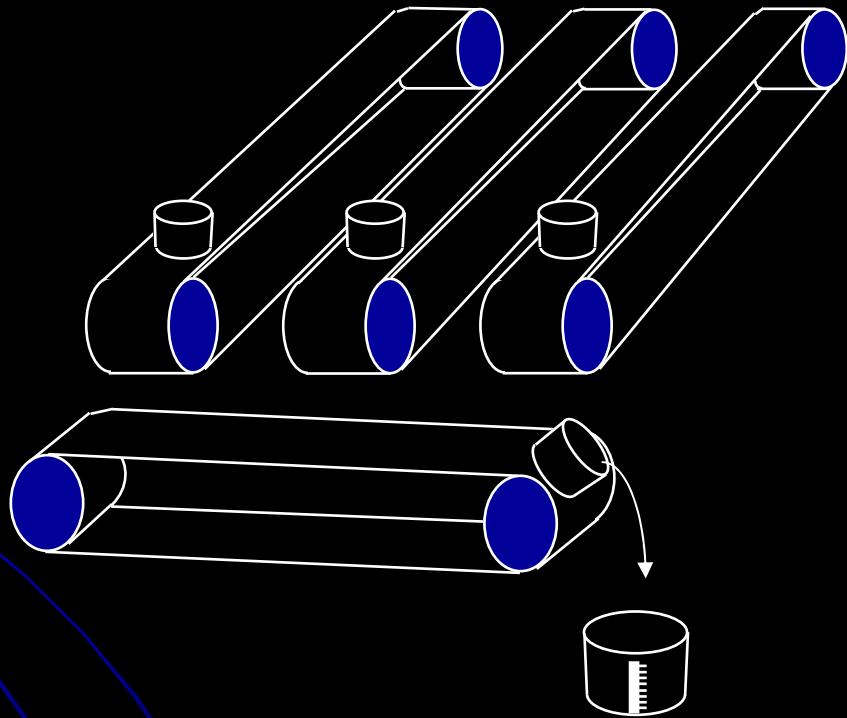

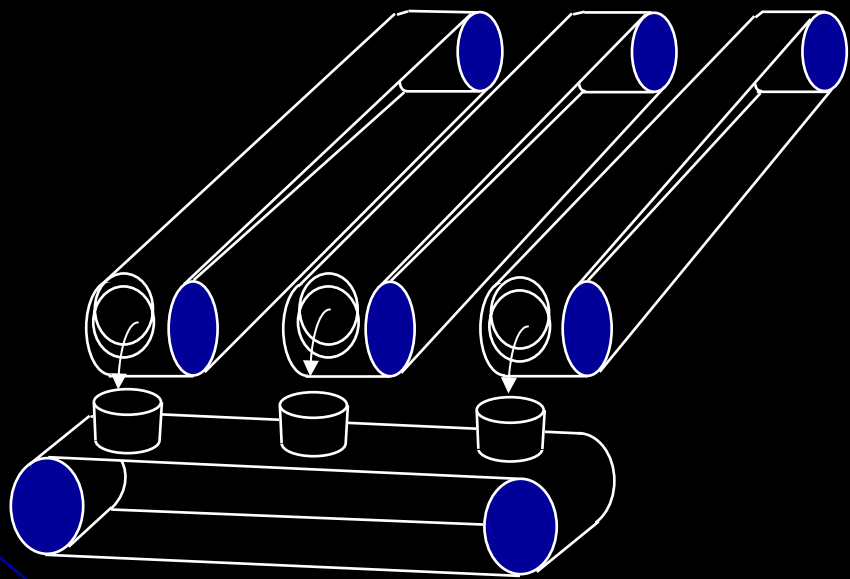

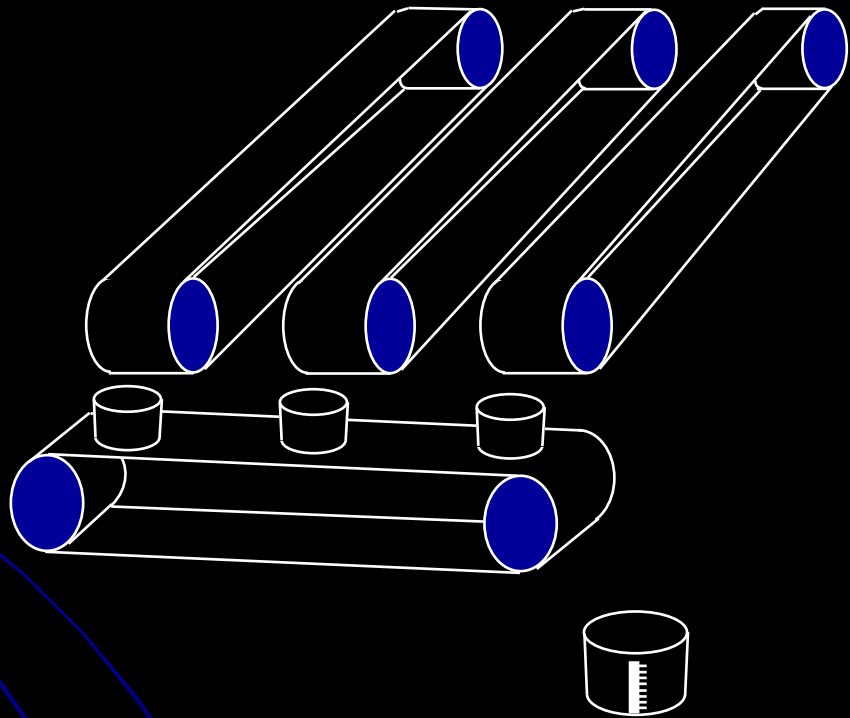

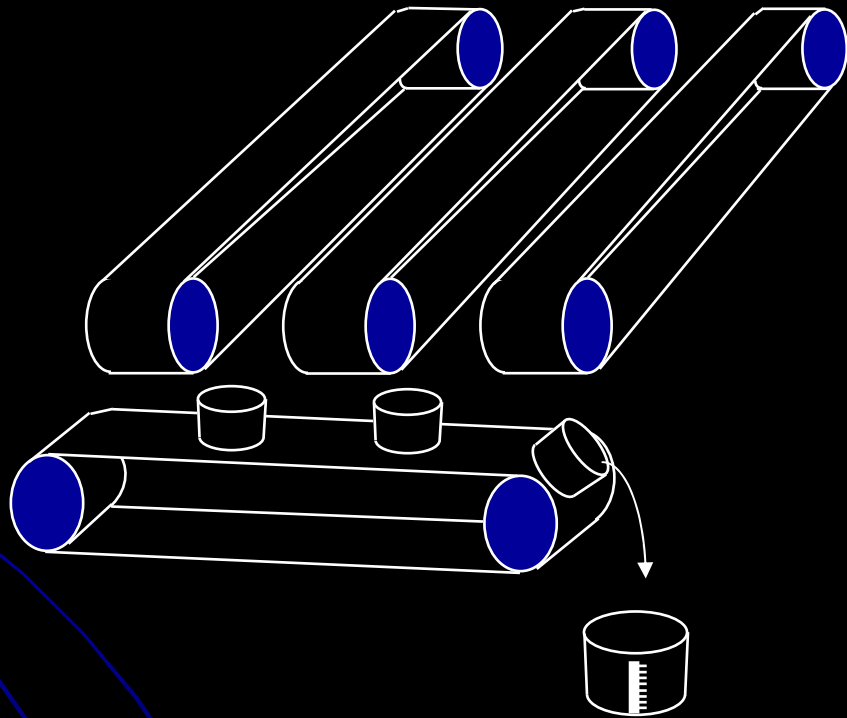

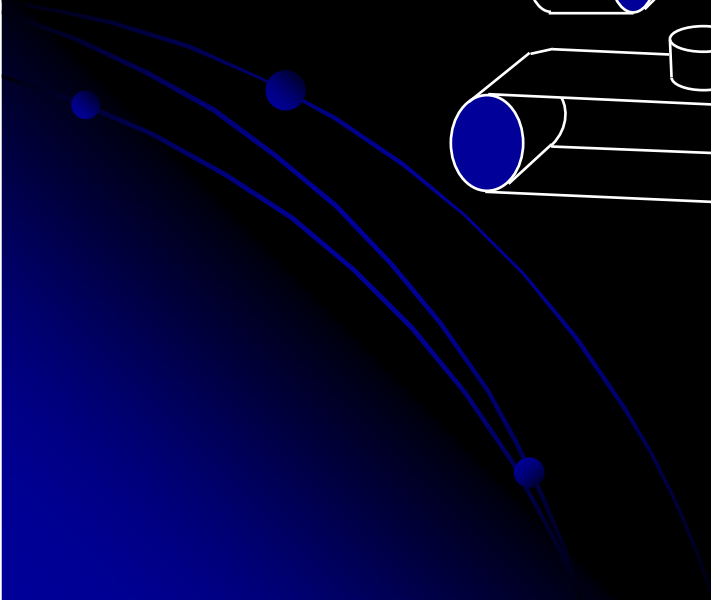
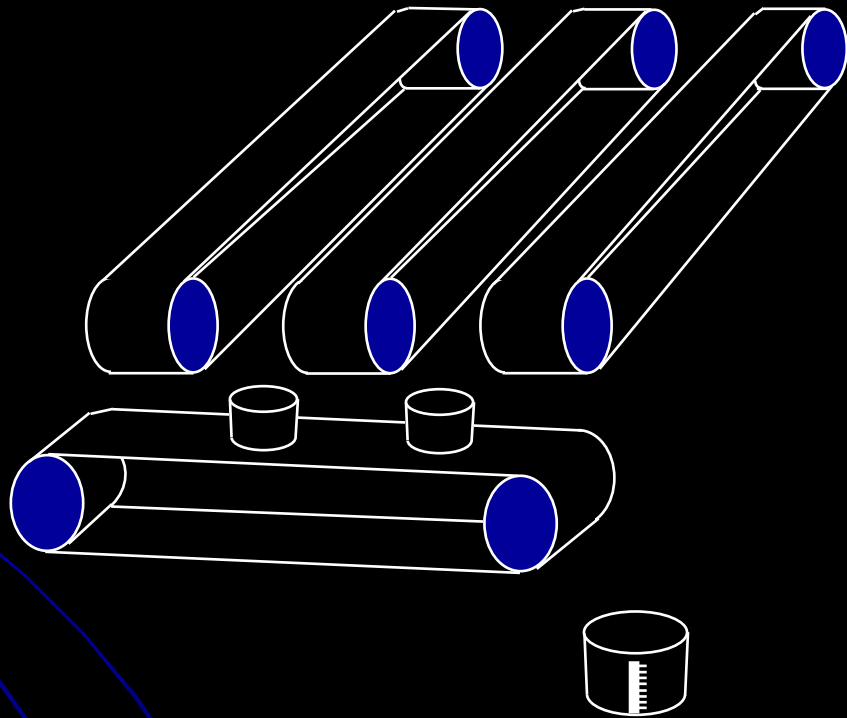

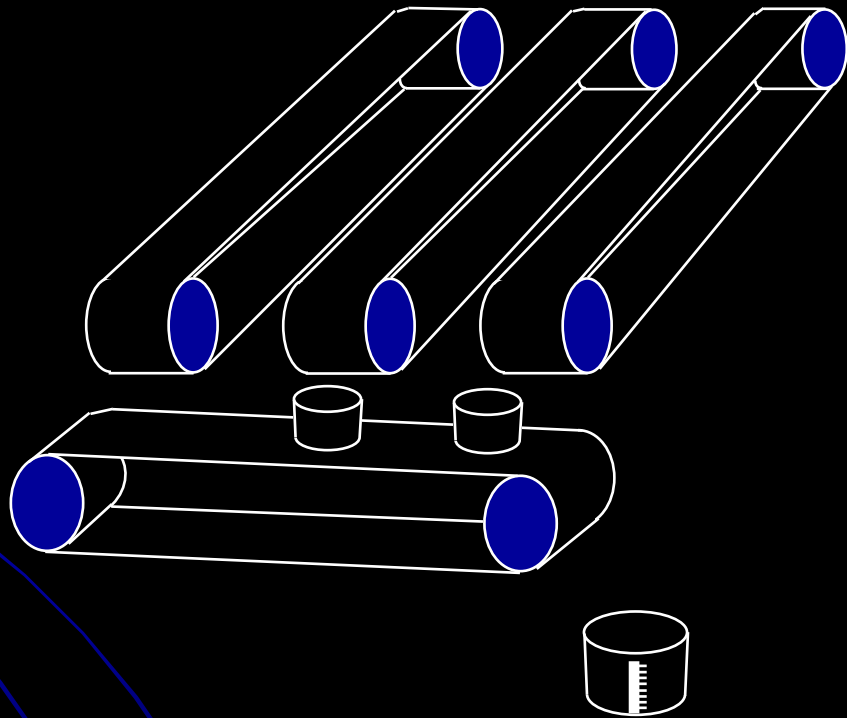

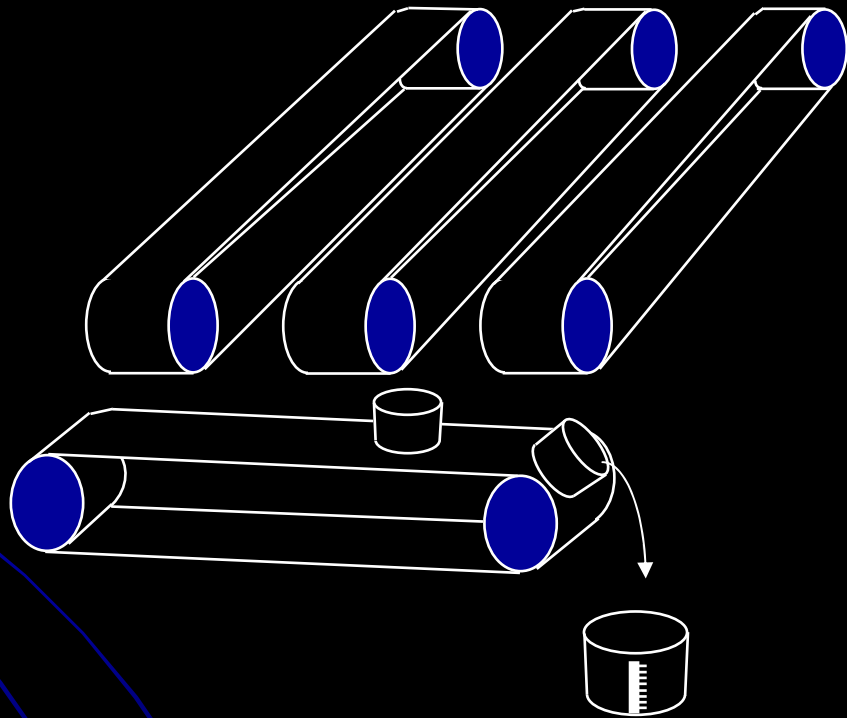

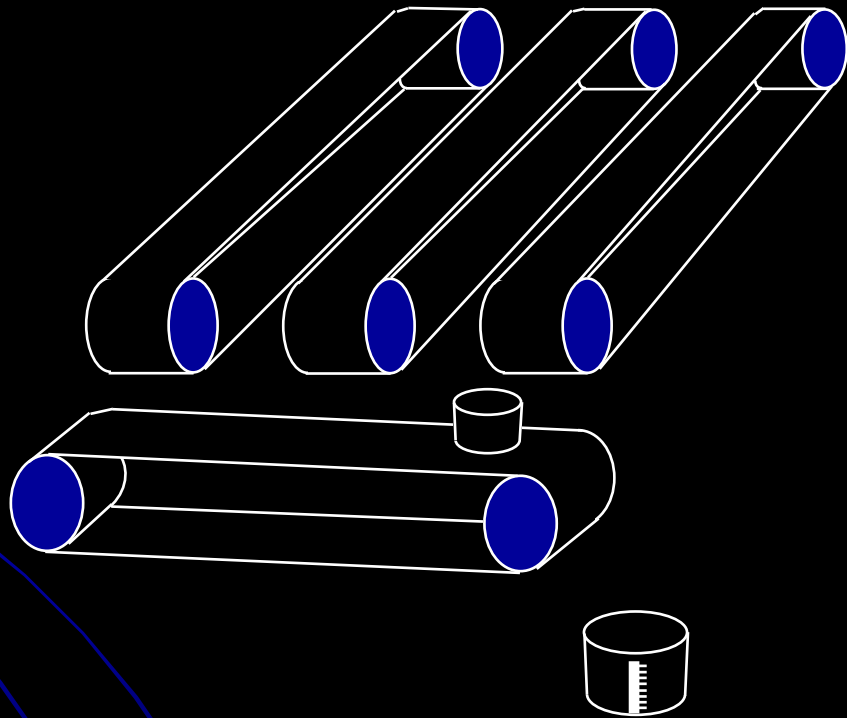

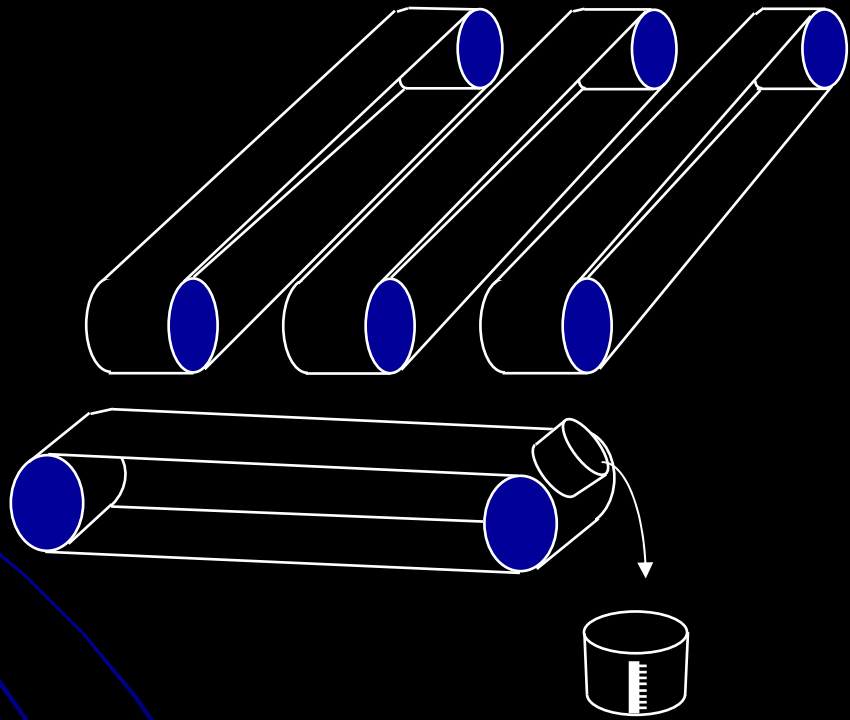

Eventually all the buckets have been measured, the CCD has been read out.

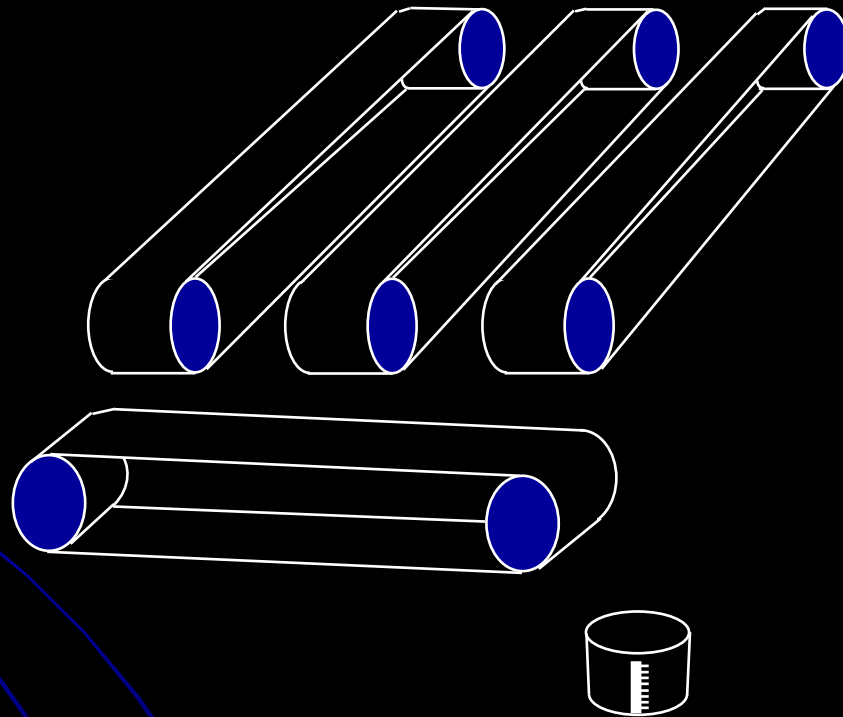

Structure of a CCD 1.

The image area of the CCD is positioned at the focal plane of the telescope. An image then builds up that consists of a pattern of electric charge. At the end of the exposure this pattern is then transferred, pixel at a time, by way of the serial register to the on-chip amplifier. Electrical connections are made to the outside world via a series of bond pads and thin gold wires positioned around the chip periphery.

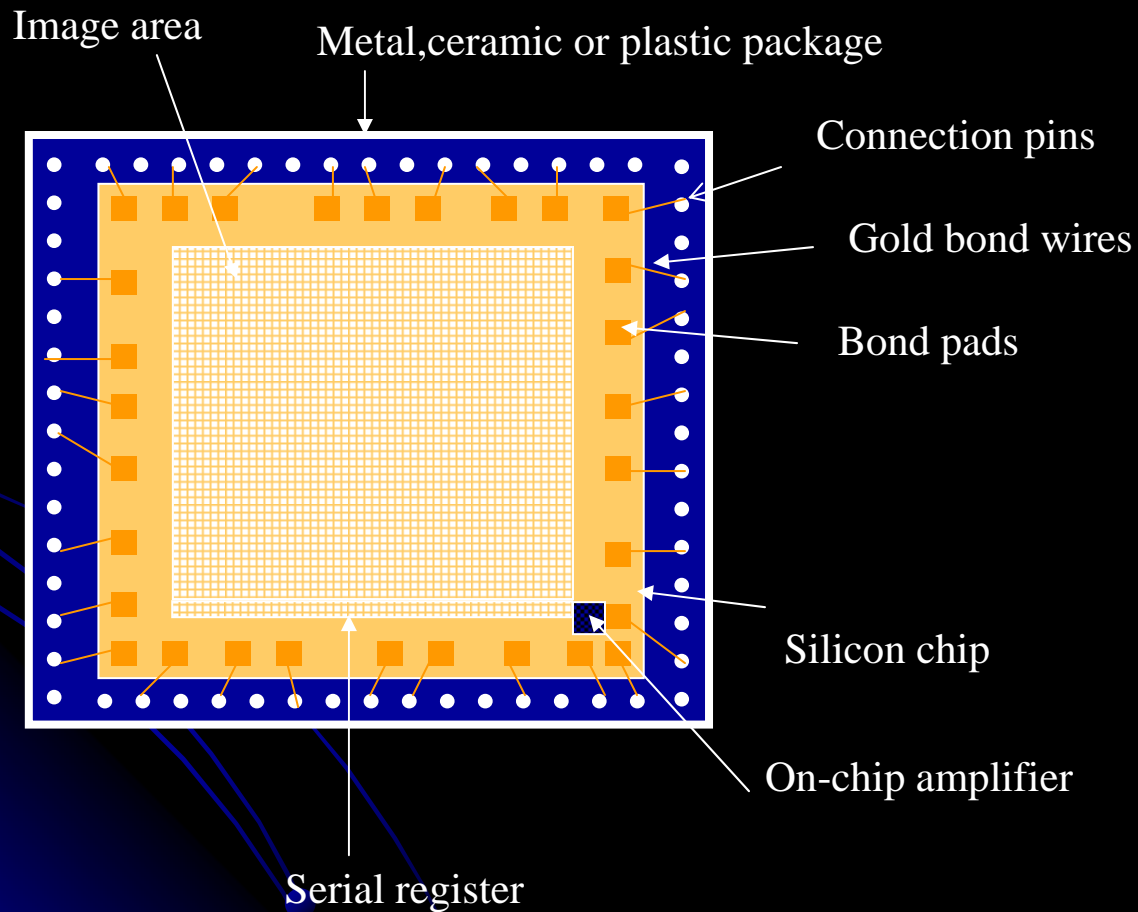

Structure of a CCD 2.

CCDs are manufactured on silicon wafers using the same photo-lithographic techniques used to manufacture computer chips. Scientific CCDs are very big, only a few can be fitted onto a wafer. This is one reason that they are so costly.

The photo below shows a silicon wafer with three large CCDs and assorted smaller devices. A CCD has been produced by Philips that fills an entire 6 inch wafer!

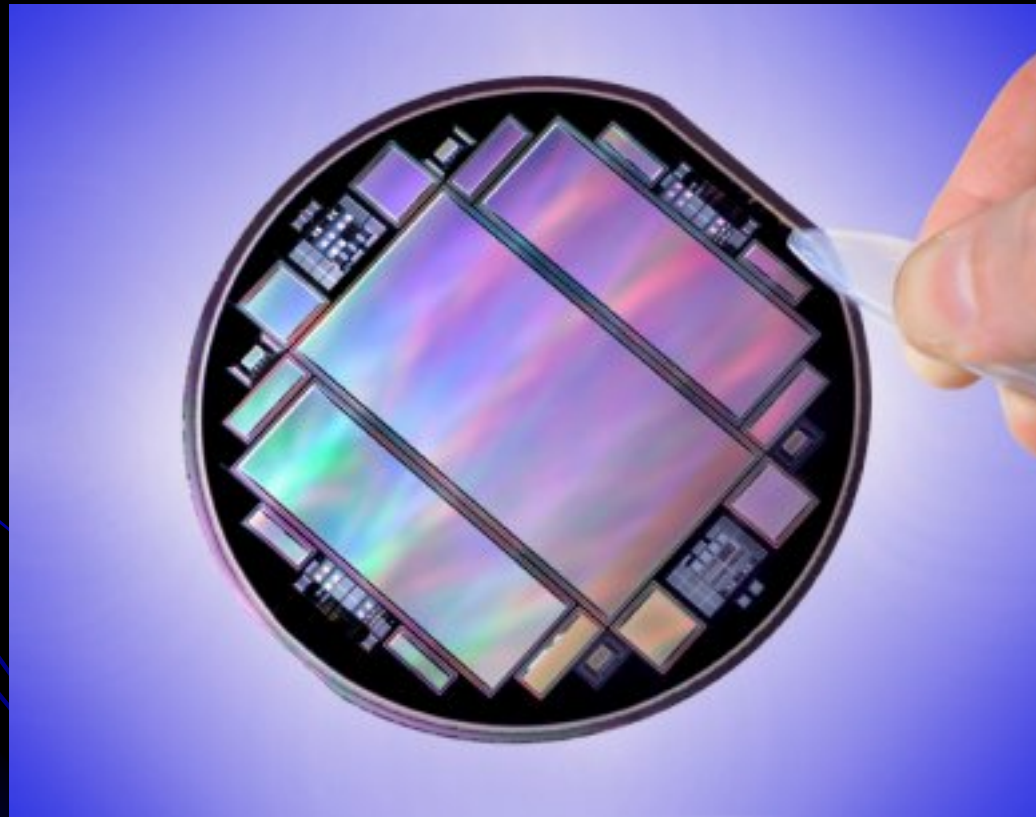

Structure of a CCD 3.

The diagram shows a small section (a few pixels) of the image area of a CCD. This pattern is repeated. Channel stops to define the columns of the image

Plan View

One pixel

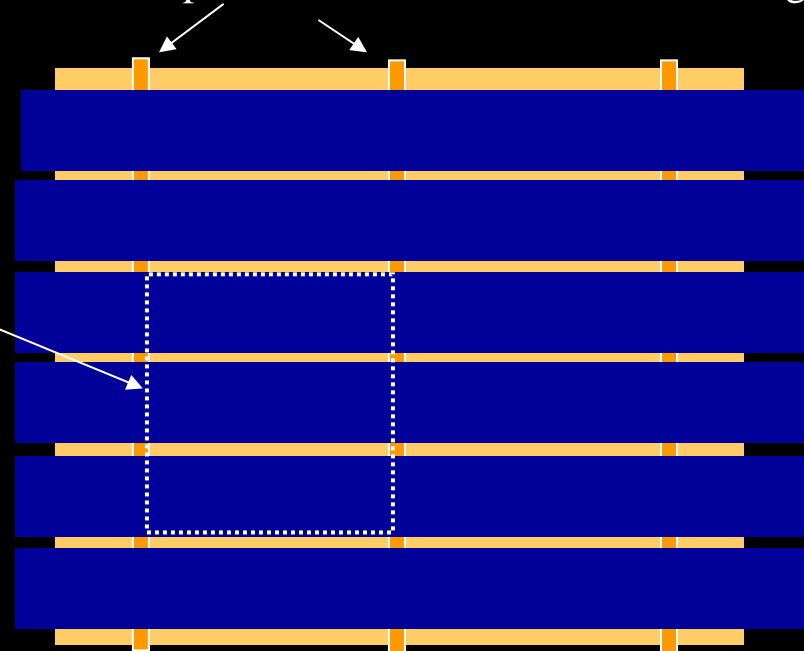

Transparent horizontal electrodes to define the pixels vertically. Also used to transfer the charge during readout

Cross section

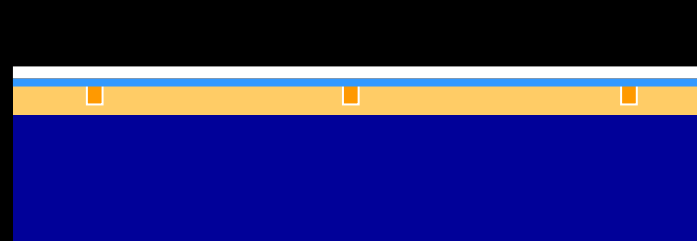

Electrode
Insulating oxide
n-type silicon
p-type silicon

Every third electrode is connected together. Bus wires running down the edge of the chip make the connection. The channel stops are formed from high concentrations of Boron in the silicon.

Structure of a CCD 4.

Below the image area (the area containing the horizontal electrodes) is the 'Serial register'. This also consists of a group of small surface electrodes. There are three electrodes for every column of the image area

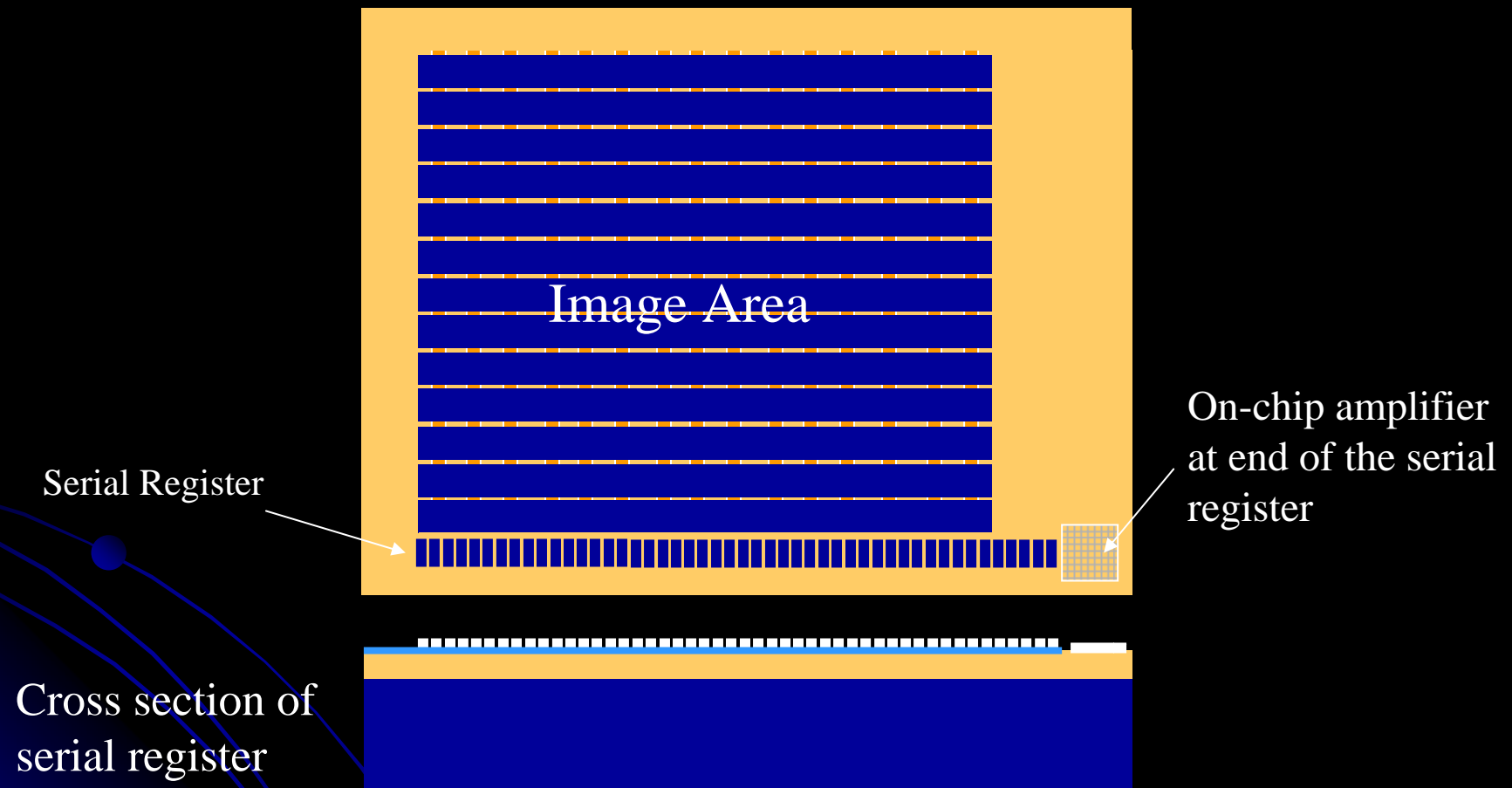

Once again every third electrode is in the serial register connected together.

Structure of a CCD 5.

Photomicrograph of a corner of an EEV CCD.

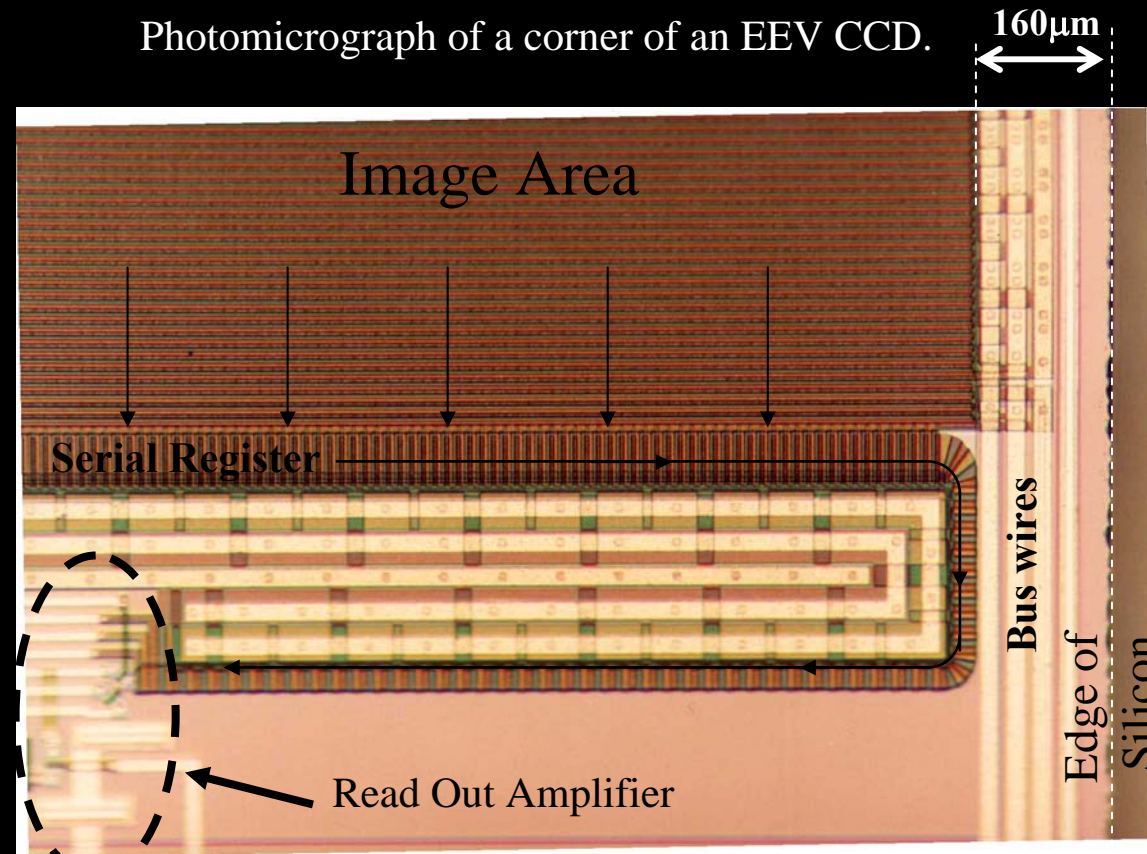

The serial register is bent double to move the output amplifier away from the edge of the chip. This is useful if the CCD is to be used as part of a mosaic. The arrows indicate how charge is transferred through the device.

Structure of a CCD 6.

Photomicrograph of the on-chip amplifier of a Tektronix CCD and its circuit diagram.

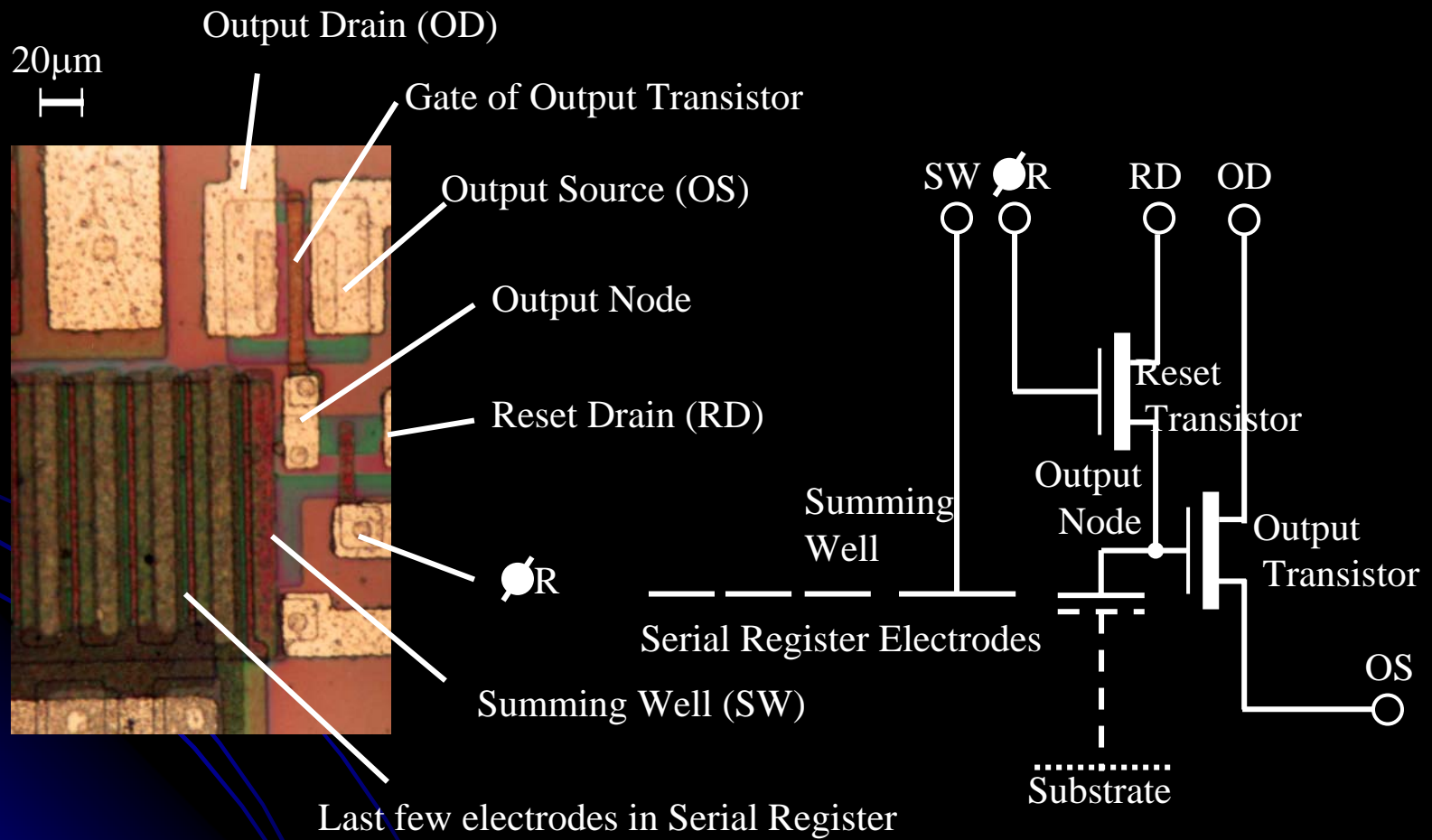

Electric Field in a CCD 1.

The n-type layer contains an excess of electrons that diffuse into the p-layer. The p-layer contains an excess of holes that diffuse into the n-layer. This structure is identical to that of a diode junction. The diffusion creates a charge imbalance and induces an internal electric field. The electric potential reaches a maximum just inside the n-layer, and it is here that any photo-generated electrons will collect. All science CCDs have this junction structure, known as a 'Buried Channel'. It has the advantage of keeping the photo-electrons confined away from the surface of the CCD where they could become trapped. It also reduces the amount of thermally generated noise (dark current).

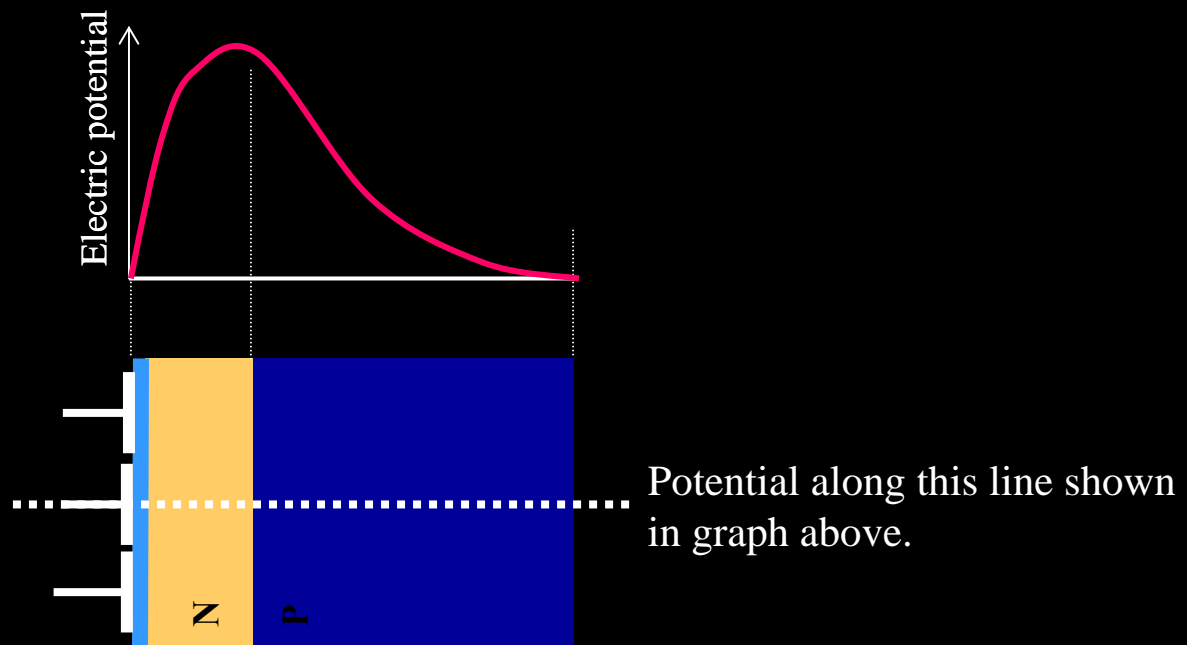

Cross section through the thickness of the CCD

Electric Field in a CCD 2.

During integration of the image, one of the electrodes in each pixel is held at a positive potential. This further increases the potential in the silicon below that electrode and it is here that the photoelectrons are accumulated. The neighboring electrodes, with their lower potentials, act as potential barriers that define the vertical boundaries of the pixel. The horizontal boundaries are defined by the channel stops.

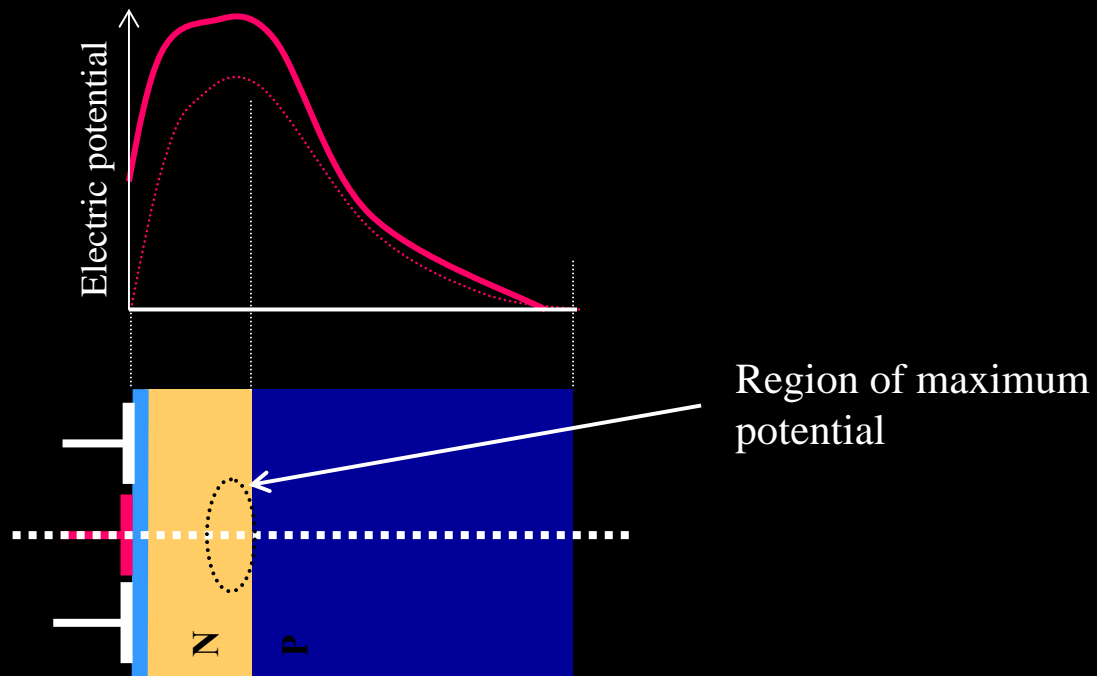



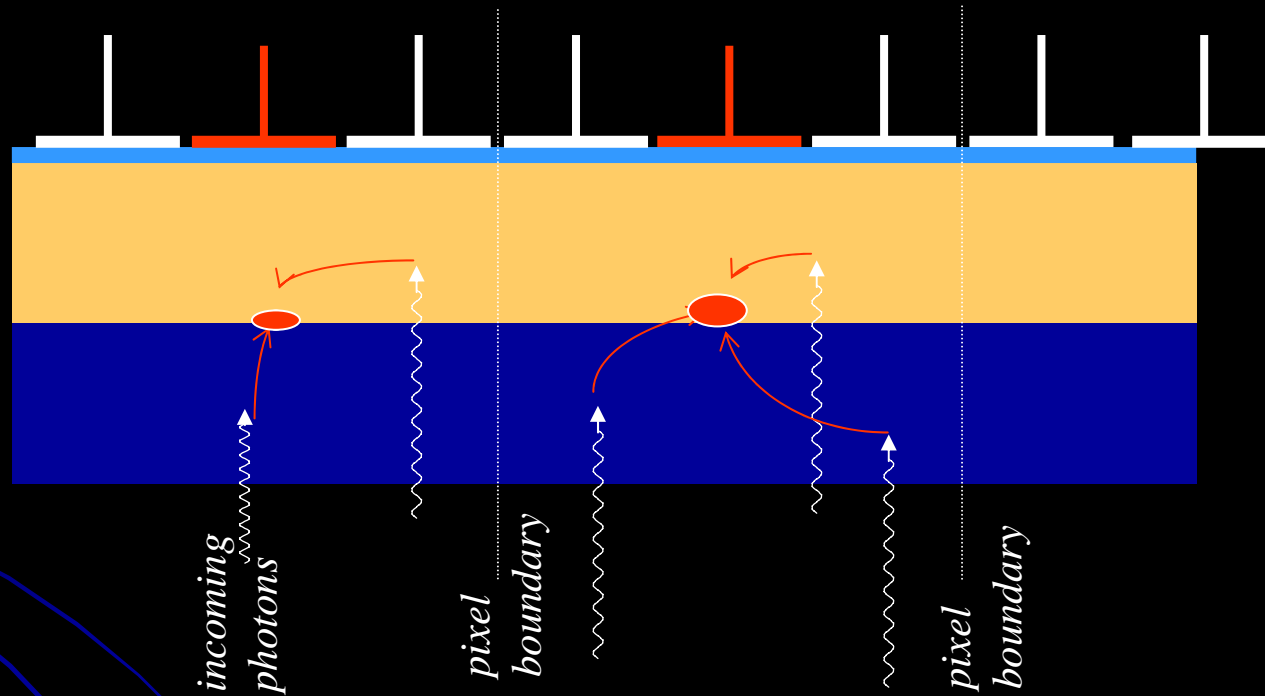

Charge Collection in a CCD.

Photons entering the CCD create electron-hole pairs. The electrons are then attracted towards the most positive potential in the device where they create 'charge packets'. Each packet corresponds to the charge of one pixel (i.e. the pixel value)



 Charge packet

 n-type silicon
 p-type silicon

 Electrode Structure
 SiO₂ Insulating layer

Charge Transfer in a CCD 1.

In the following few slides, the implementation of the 'conveyor belts' as actual electronic structures is explained.

The charge is moved along these conveyor belts by modulating the voltages on the electrodes positioned on the surface of the CCD. In the following illustrations, electrodes colour coded red are held at a positive potential, those coloured black are held at a negative potential.

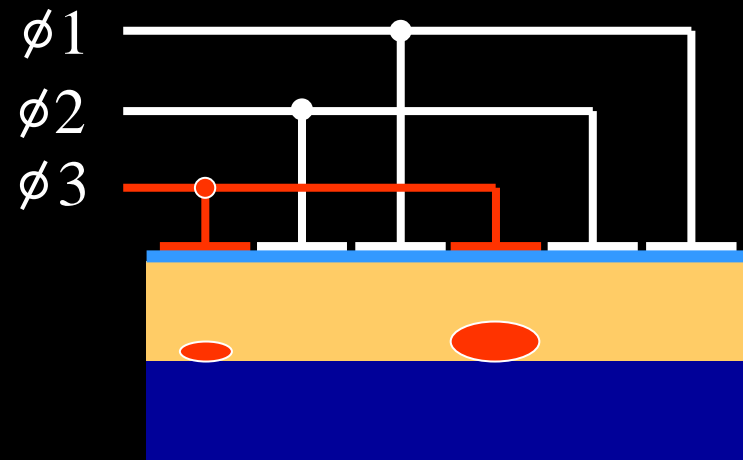

Charge Transfer in a CCD 2.

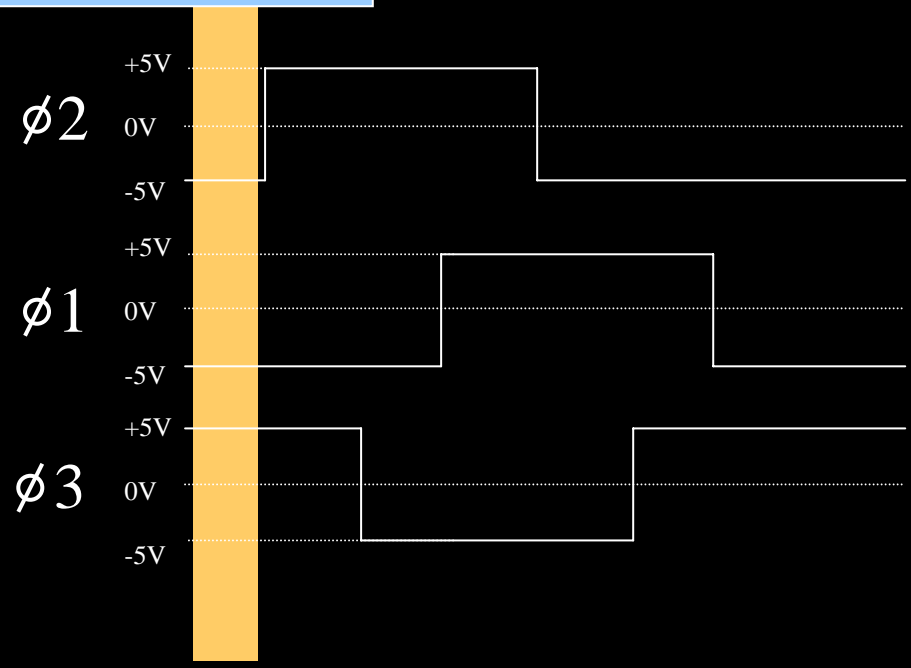
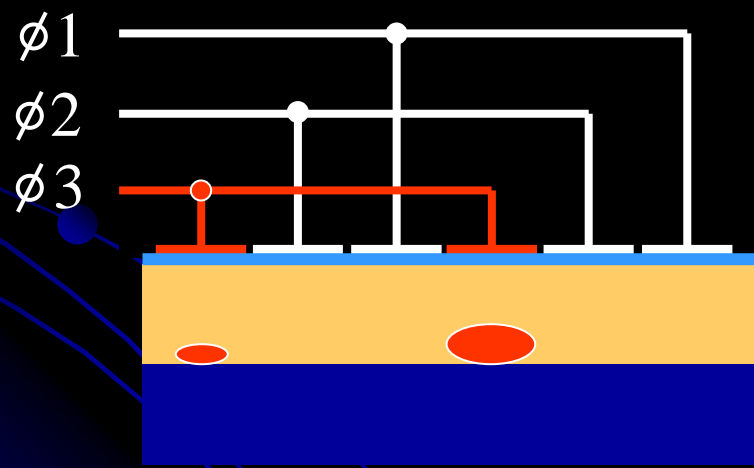

Time-slice shown in diagram

Charge Transfer in a CCD 3.

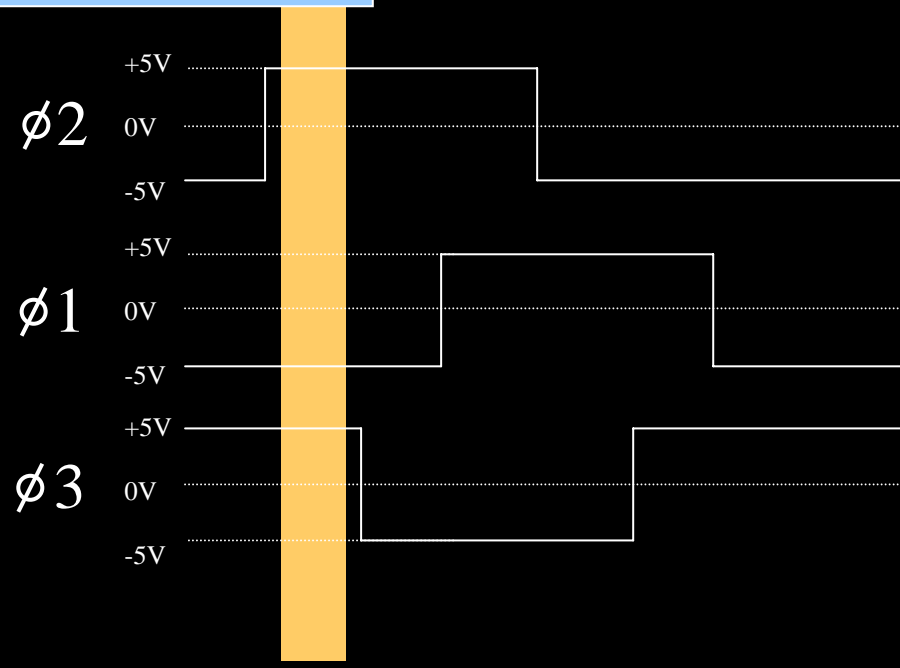
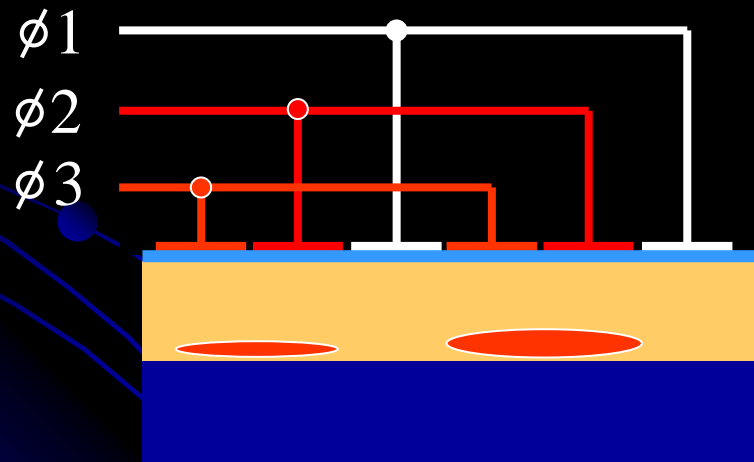

Charge Transfer in a CCD 4.

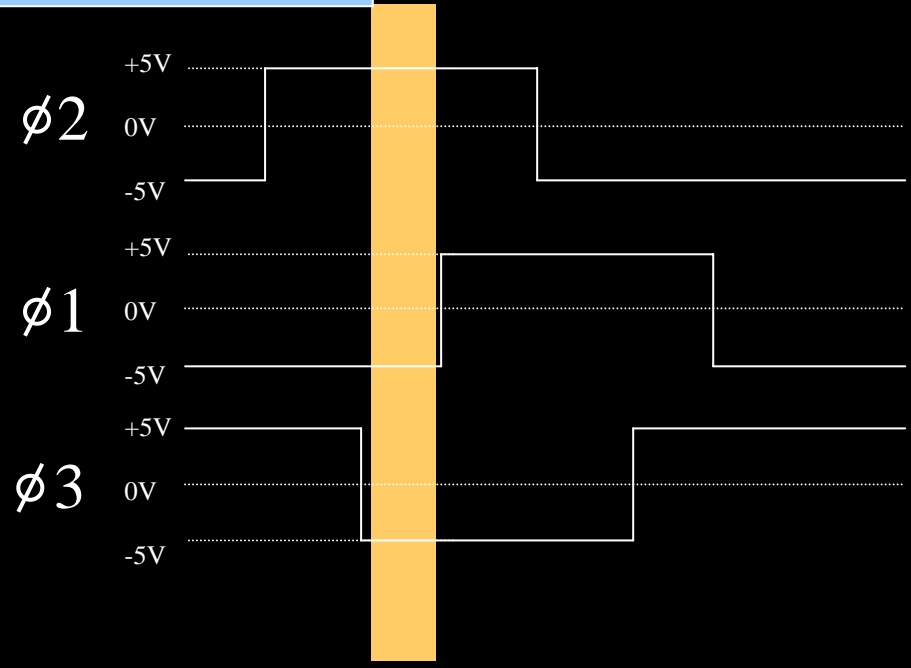
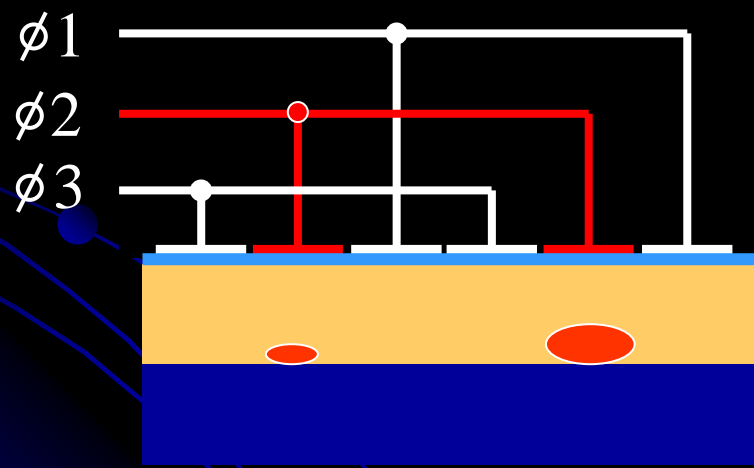

Charge Transfer in a CCD 5.

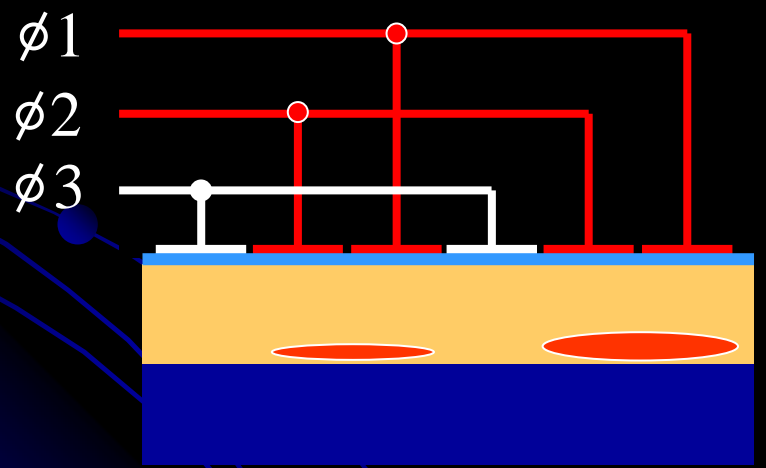
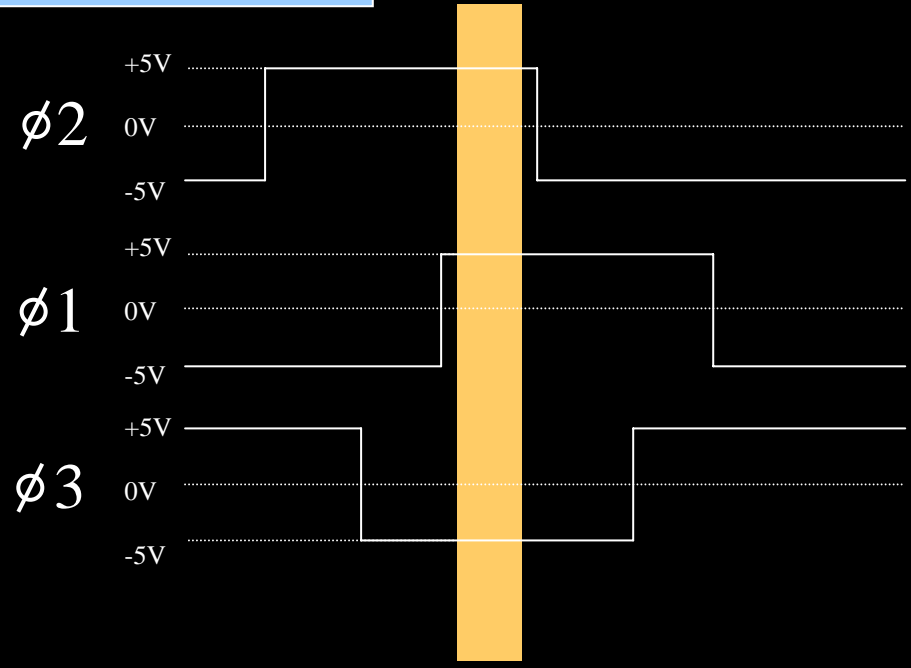

Charge Transfer in a CCD 6.

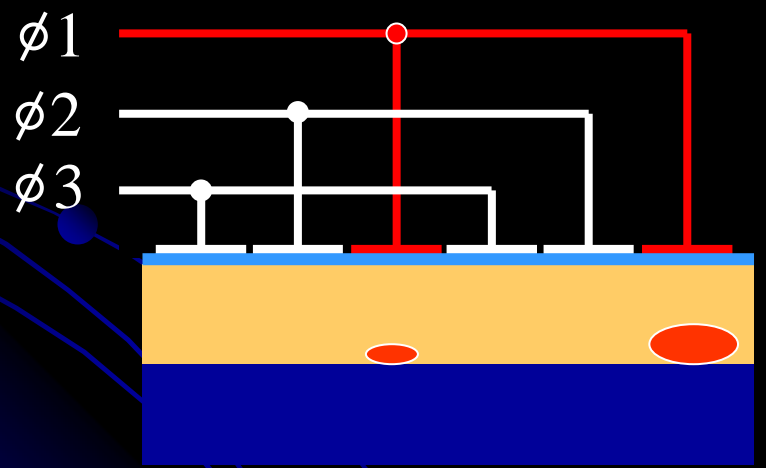
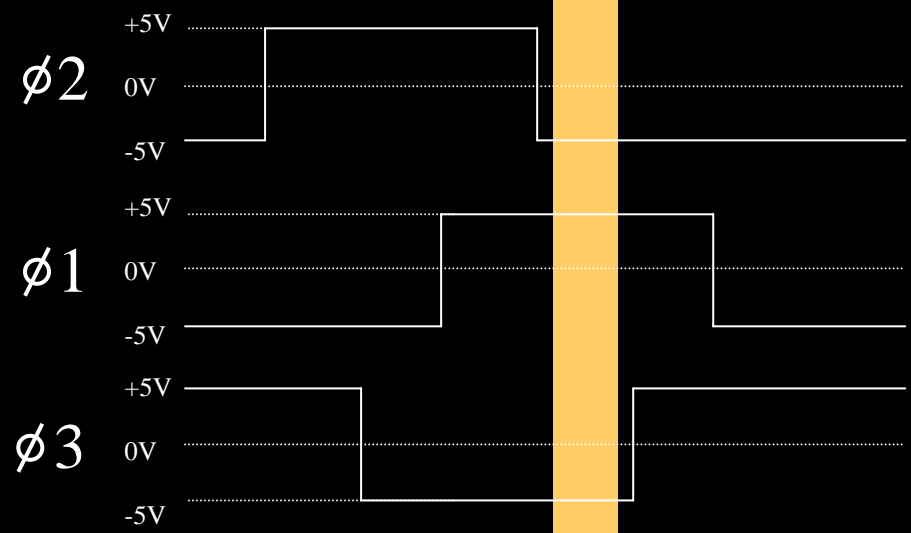

Charge Transfer in a CCD 7.

Charge packet from subsequent pixel enters from left as first pixel exits to the right.

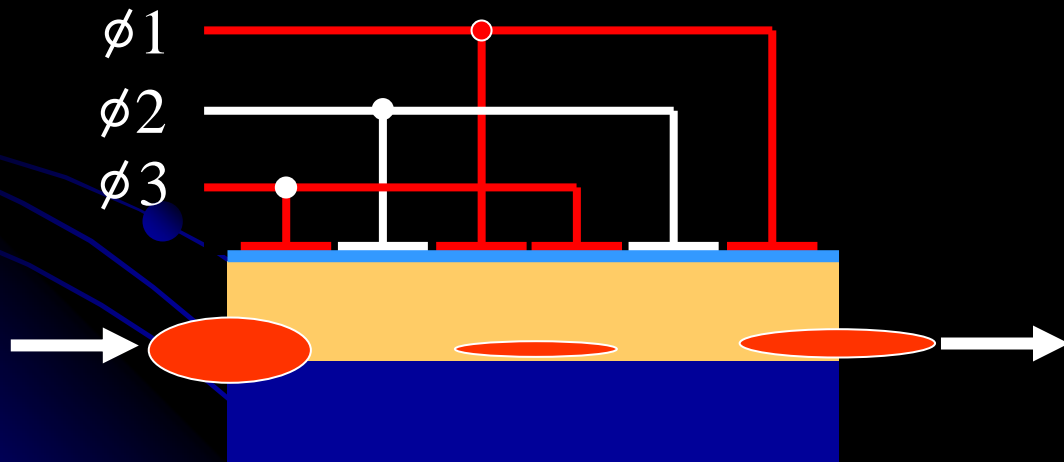
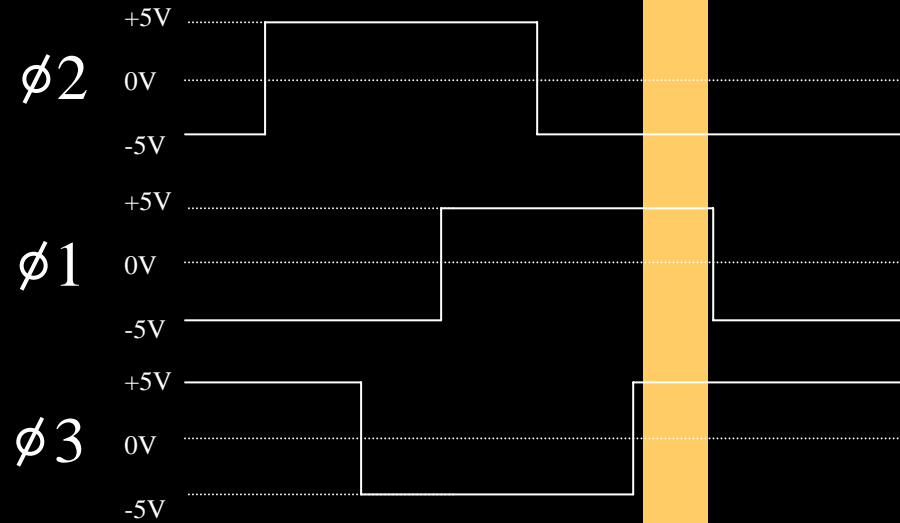

Charge Transfer in a CCD 8.

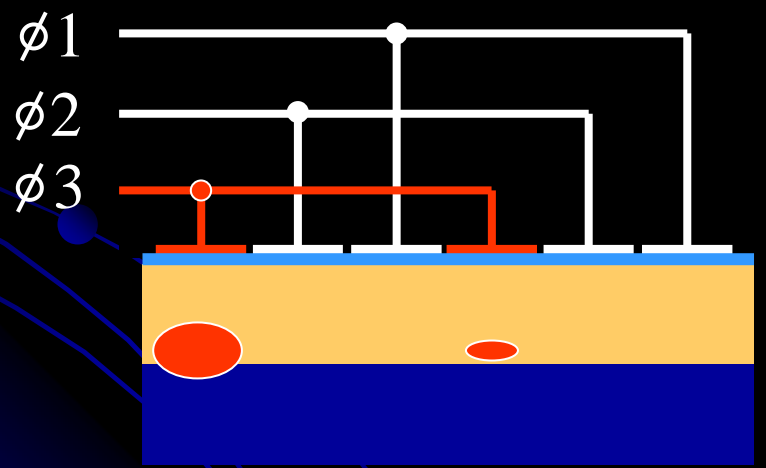
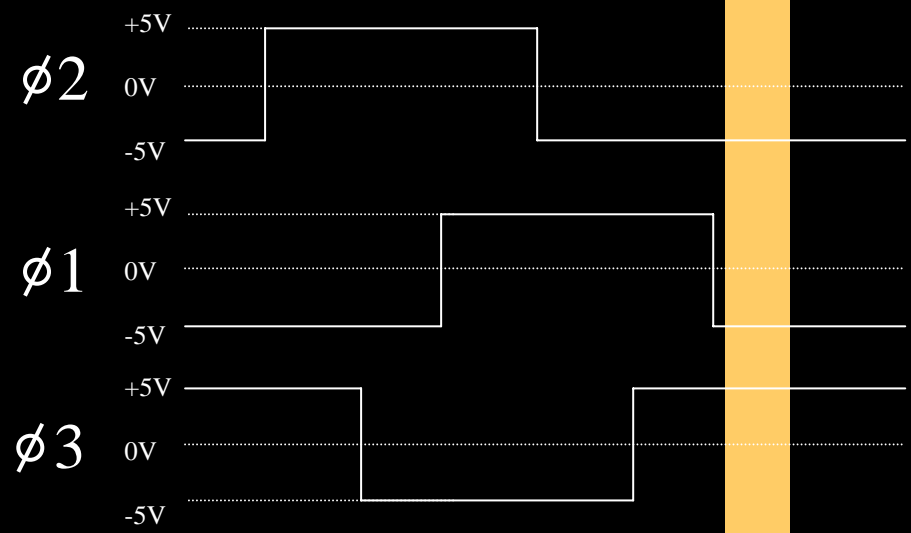

On-Chip Amplifier 1.

The on-chip amplifier measures each charge packet as it pops out the end of the serial register.

RD and OD are held at constant voltages

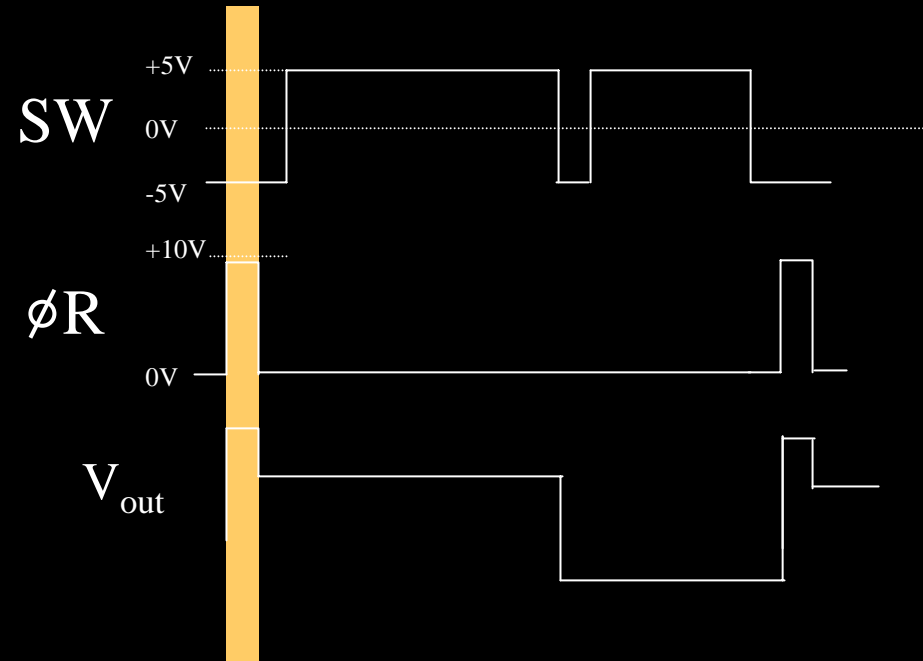
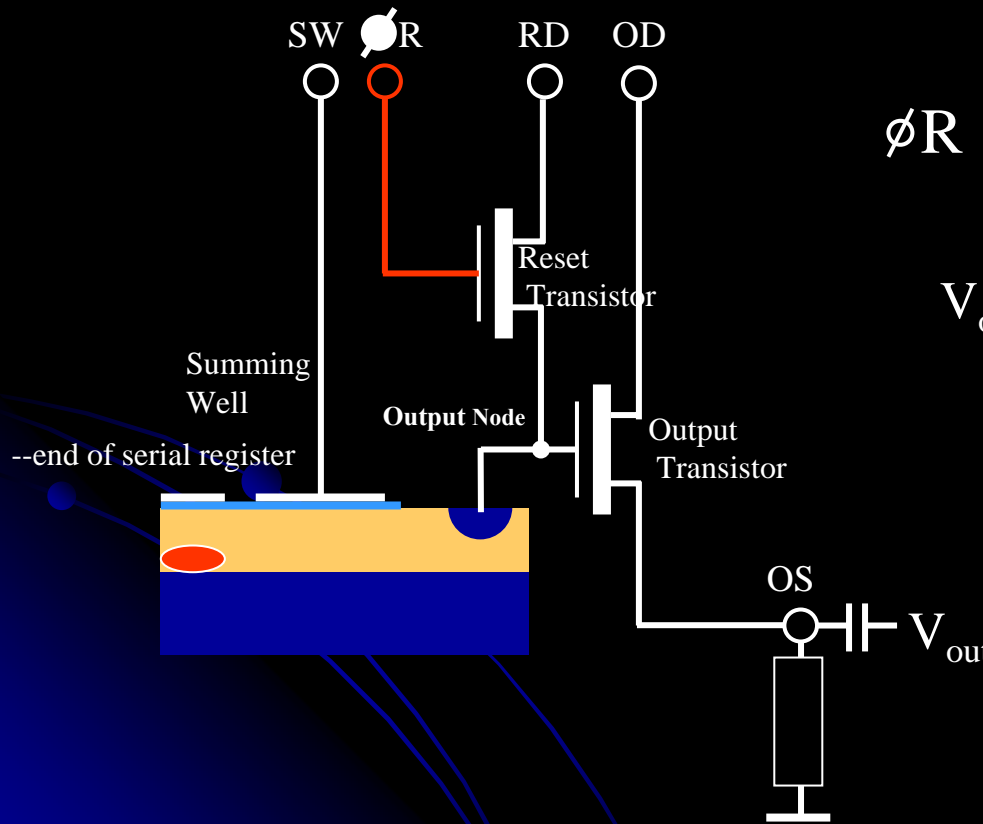

(The graphs above show the signal waveforms)

The measurement process begins with a reset of the 'reset node'. This removes the charge remaining from the previous pixel. The reset node is in fact a tiny capacitance ($< 0.1\text{pF}$)

On-Chip Amplifier 2.

The charge is then transferred onto the Summing Well. V_{out} is now at the 'Reference level'

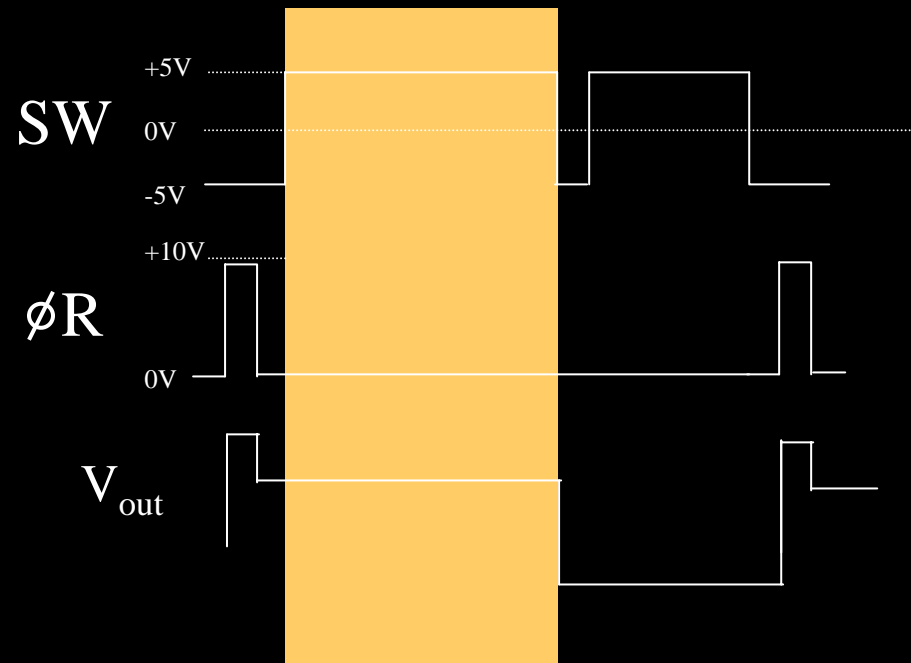
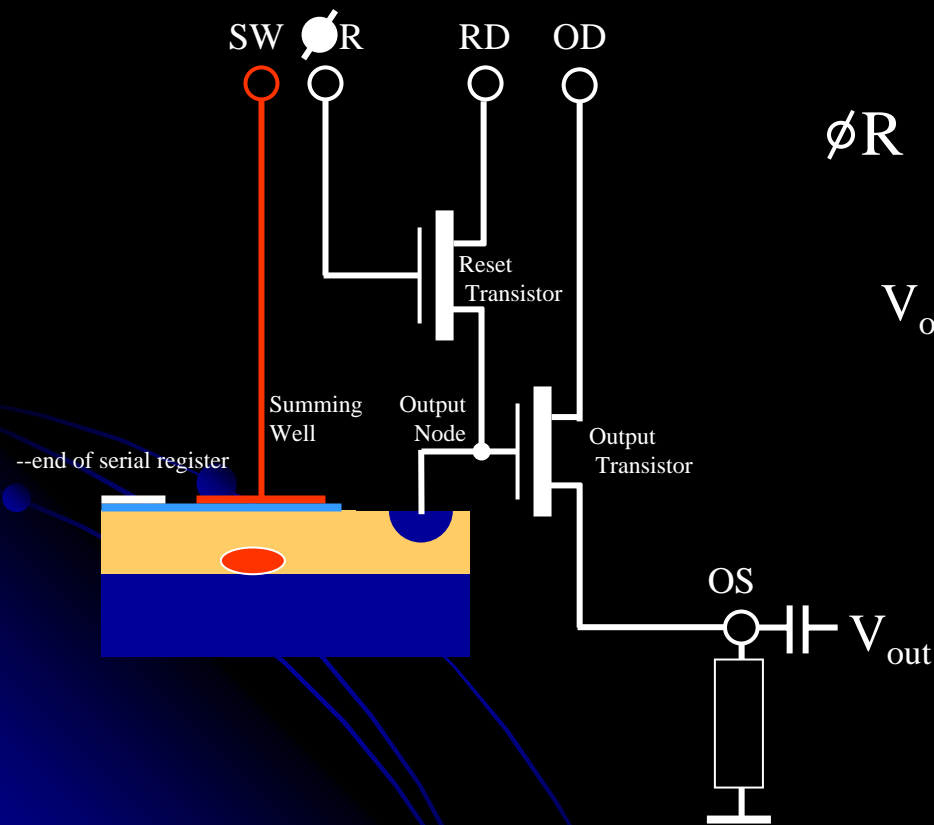

There is now a wait of up to a few tens of microseconds while external circuitry measures this 'reference' level.

On-Chip Amplifier 3.

The charge is then transferred onto the output node. V_{out} now steps down to the 'Signal level'

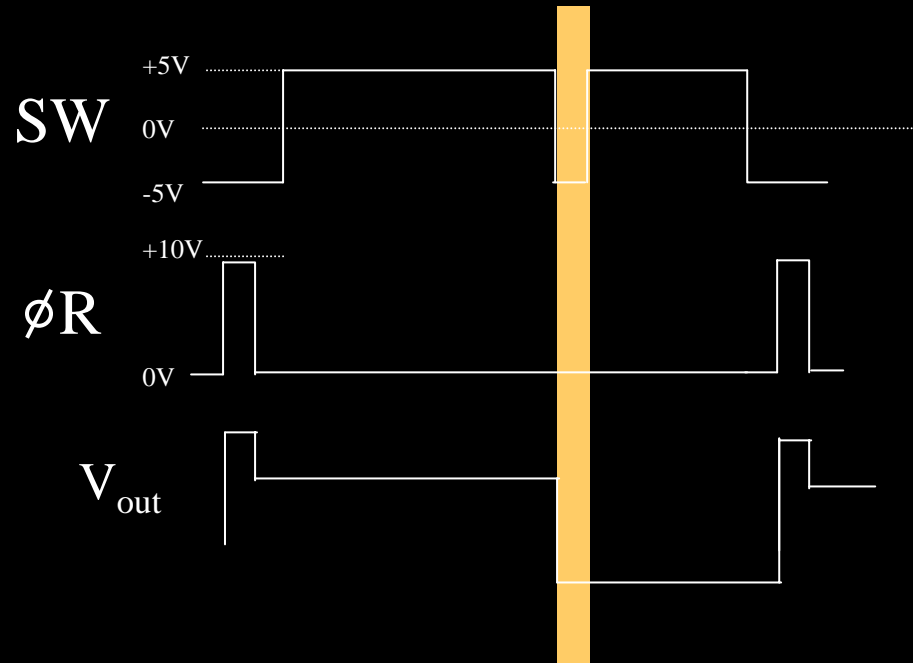
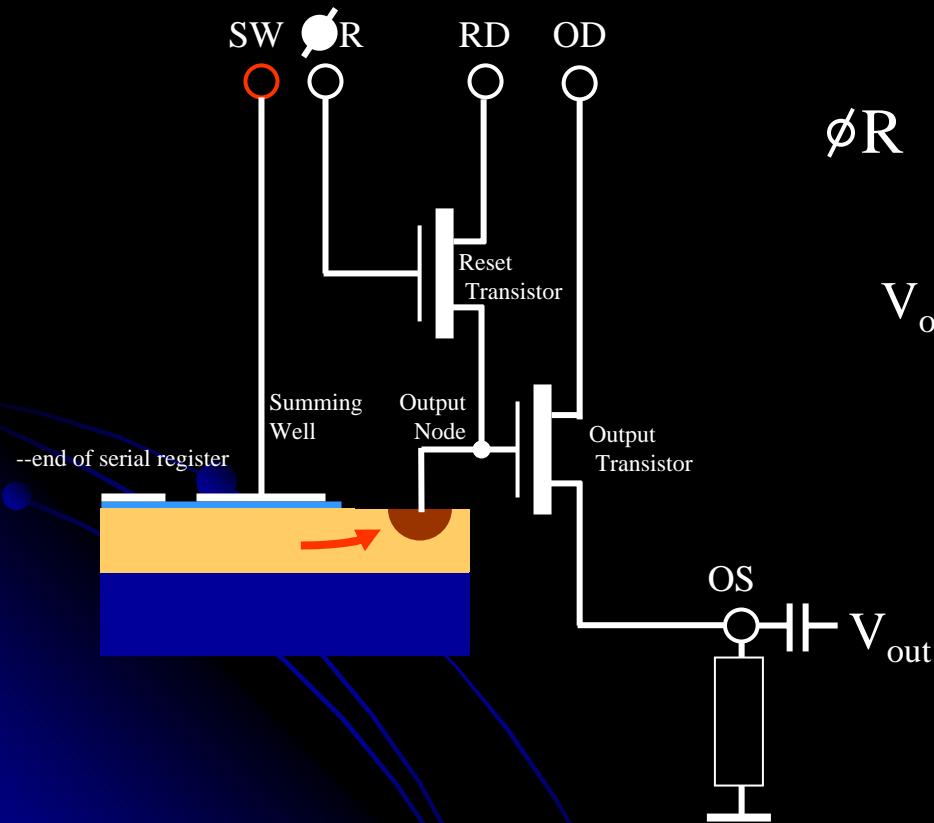

This action is known as the 'charge dump'. The voltage step in V_{out} is as much as several μV for each electron contained in the charge packet.

On-Chip Amplifier 4.

V_{out} is now sampled by external circuitry for up to a few tens of microseconds.

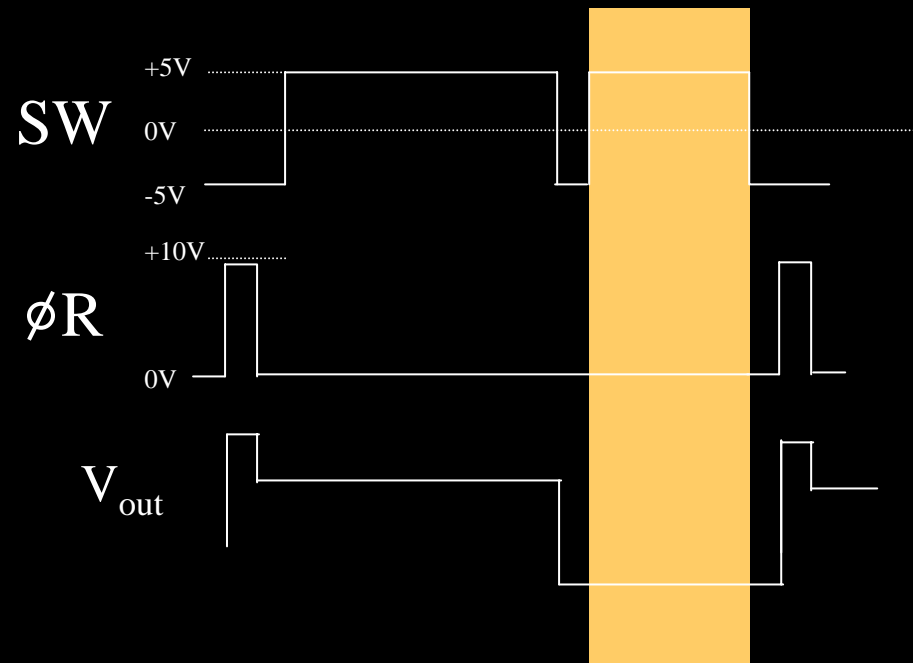
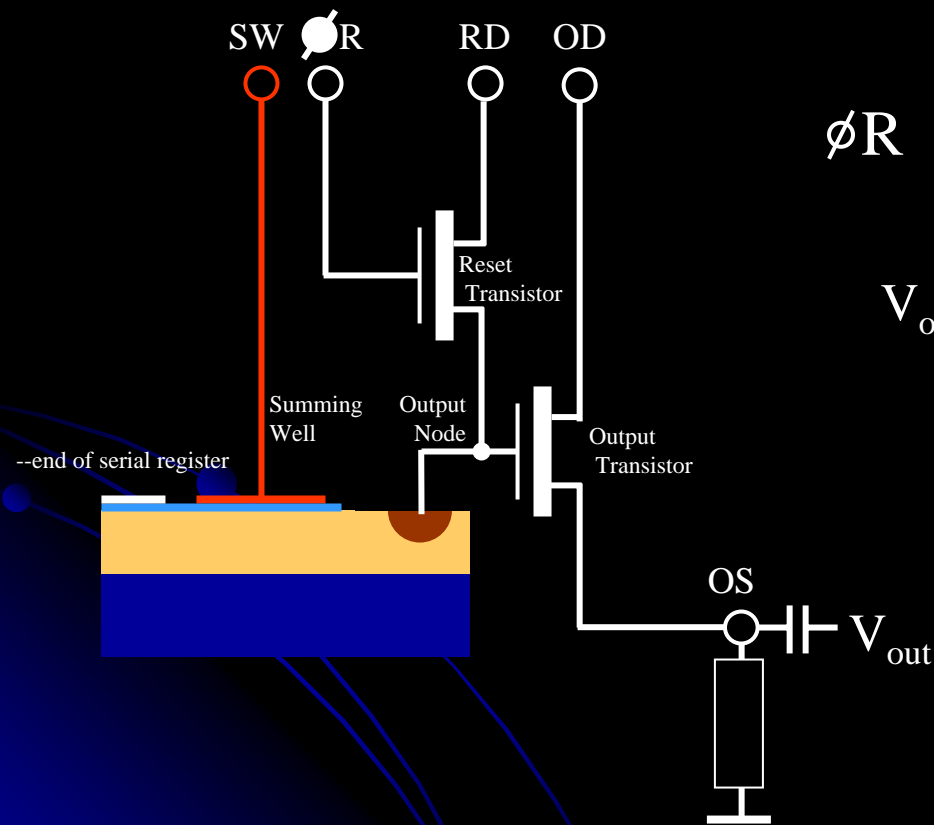

The sample level - reference level will be proportional to the size of the input charge packet.

Chapter 2 : Use of CCD Cameras.

In this activity some of the practical considerations of using and building CCD cameras are described.

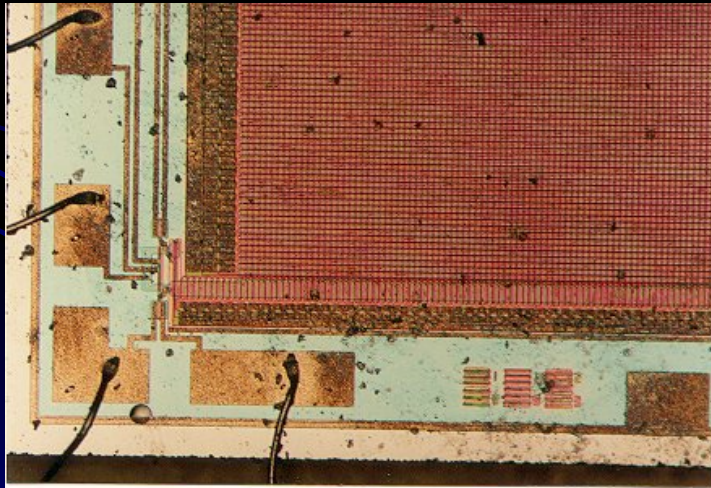

Nik Szymanek

Spectral Sensitivity of CCDs

The graph below shows the transmission of the atmosphere when looking at objects at the zenith. The atmosphere absorbs strongly below about 330nm, in the near ultraviolet part of the spectrum. An ideal CCD should have a good sensitivity from 330nm to approximately 1000nm, at which point silicon, from which CCDs are manufactured, becomes transparent and therefore insensitive.

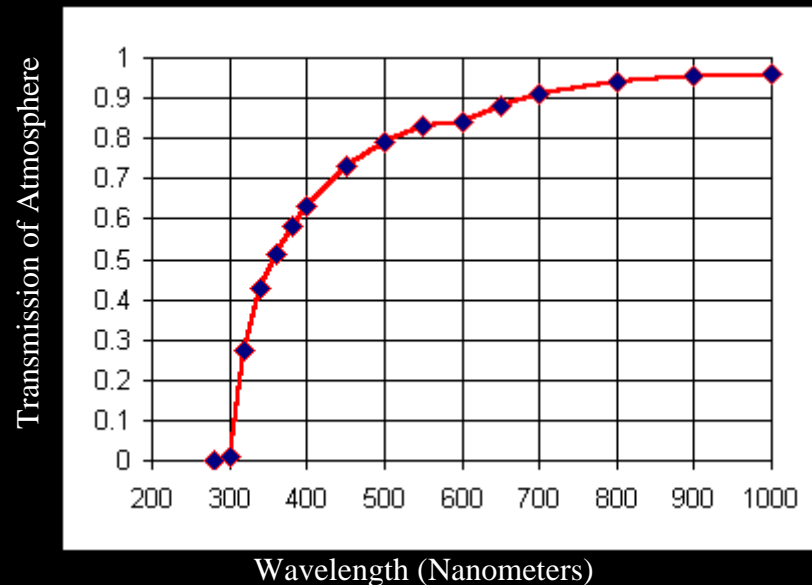

Over the last 25 years of development, the sensitivity of CCDs has improved enormously, to the point where almost all of the incident photons across the visible spectrum are detected. CCD sensitivity has been improved using two main techniques : ‘thinning’ and the use of anti-reflection coatings. These are now explained in more detail.

Thick Front-side Illuminated CCD

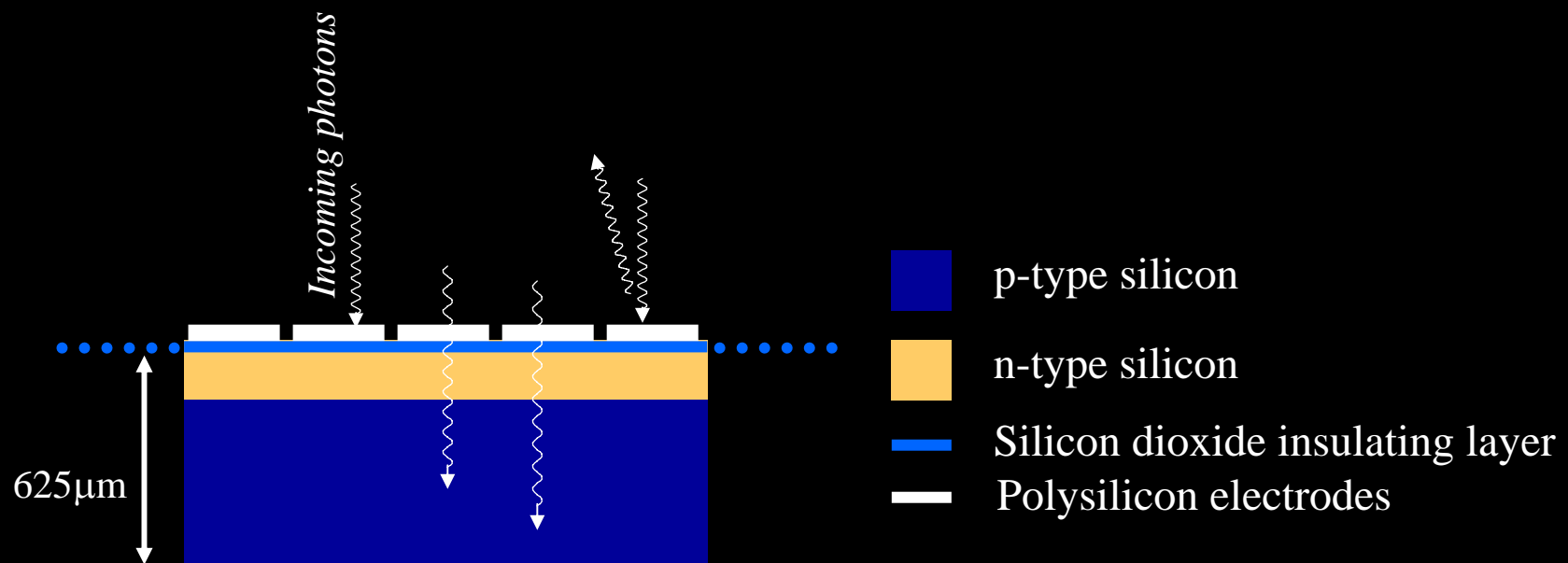

These are cheap to produce using conventional wafer fabrication techniques. They are used in consumer imaging applications. Even though not all the photons are detected, these devices are still more sensitive than photographic film.

They have a low Quantum Efficiency due to the reflection and absorption of light in the surface electrodes. Very poor blue response. The electrode structure prevents the use of an Anti-reflective coating that would otherwise boost performance.

The amateur astronomer on a limited budget might consider using thick CCDs. For professional observatories, the economies of running a large facility demand that the detectors be as sensitive as possible; thick front-side illuminated chips are seldom if ever used.

Anti-Reflection Coatings 1

Silicon has a very high Refractive Index (denoted by n). This means that photons are strongly reflected from its surface.

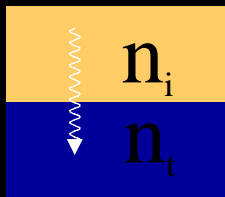

Fraction of photons reflected at the interface between two mediums of differing refractive indices = $\left[\frac{n_t - n_i}{n_t + n_i} \right]^2$

n of air or vacuum is 1.0, glass is 1.46, water is 1.33, Silicon is 3.6. Using the above equation we can show that window glass in air reflects 3.5% and silicon in air reflects 32%. Unless we take steps to eliminate this reflected portion, then a silicon CCD will at best only detect 2 out of every 3 photons.

The solution is to deposit a thin layer of a transparent dielectric material on the surface of the CCD. The refractive index of this material should be between that of silicon and air, and it should have an optical thickness = $1/4$ wavelength of light. The question now is what wavelength should we choose, since we are interested in a wide range of colours. Typically 550nm is chosen, which is close to the middle of the optical spectrum.

Anti-Reflection Coatings 2

With an Anti-reflective coating we now have three mediums to consider :

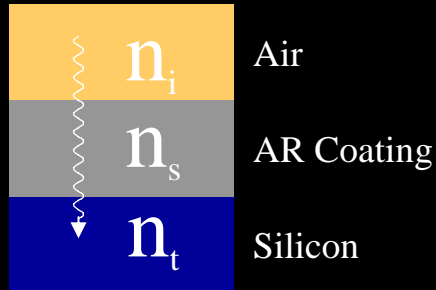

The reflected portion is now reduced to :

$$\left[\frac{n_t \times n_i - n_s^2}{n_t \times n_i + n_s^2} \right]^2$$

In the case where $n_s^2 = n_i \times n_t$ the reflectivity actually falls to zero! For silicon we require a material with $n = 1.9$, fortunately such a material exists, it is Hafnium Dioxide. It is regularly used to coat astronomical CCDs.

Anti-Reflection Coatings 3

The graph below shows the reflectivity of an EEV 42-80 CCD. These thinned CCDs were designed for a maximum blue response and it has an anti-reflective coating optimised to work at 400nm. At this wavelength the reflectivity falls to approximately 1%.

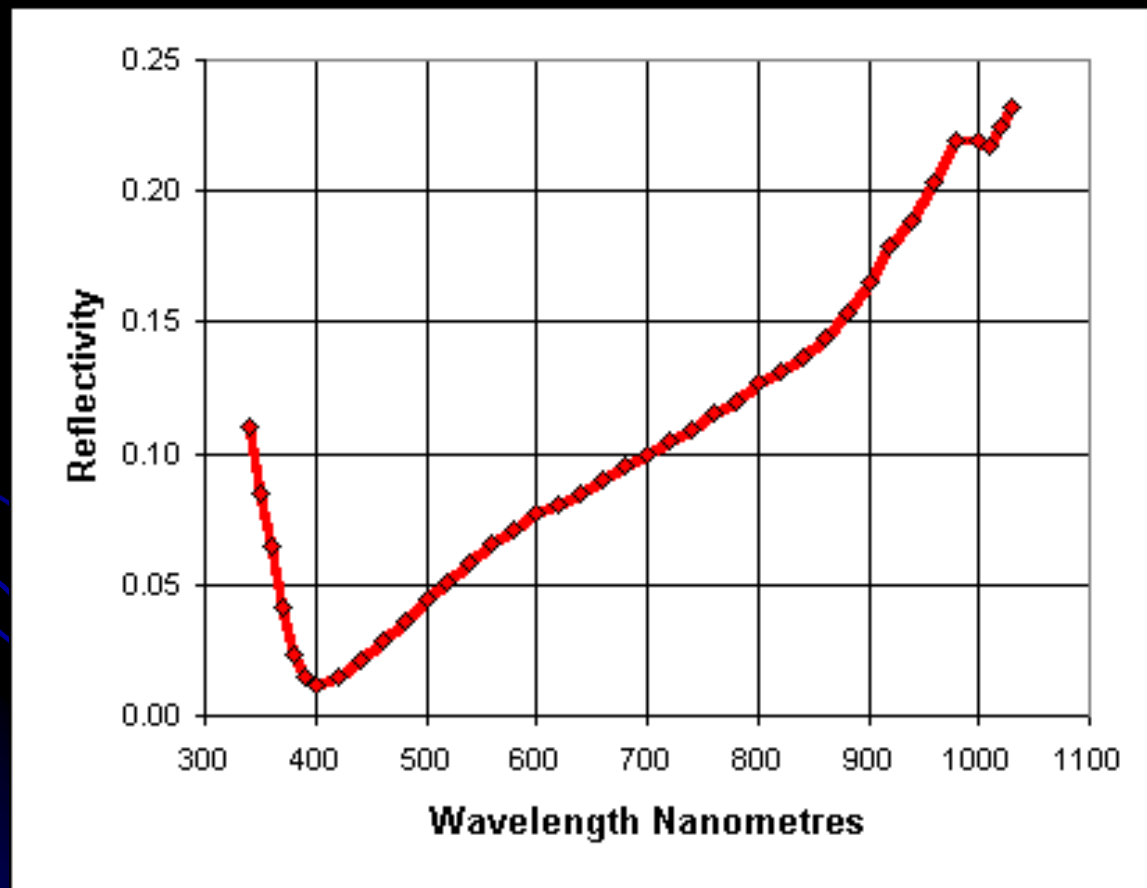

Thinned Back-side Illuminated CCD

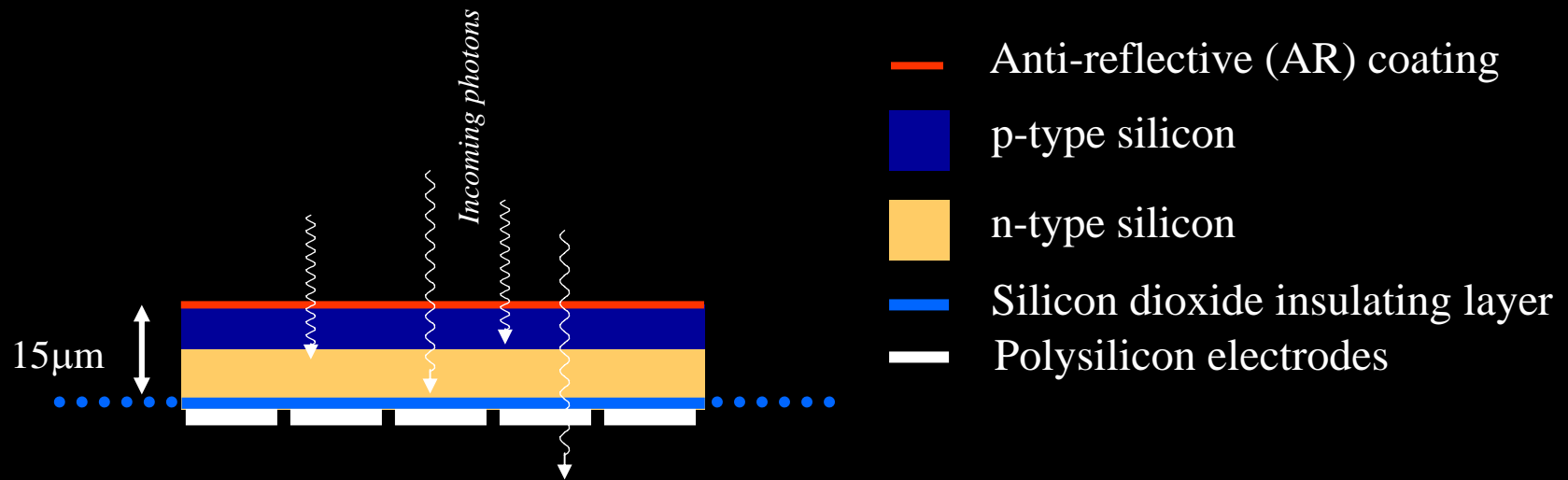

The silicon is chemically etched and polished down to a thickness of about 15microns. Light enters from the rear and so the electrodes do not obstruct the photons. The QE can approach 100% .

These are very expensive to produce since the thinning is a non-standard process that reduces the chip yield. These thinned CCDs become transparent to near infra-red light and the red response is poor. Response can be boosted by the application of an anti-reflective coating on the thinned rear-side. These coatings do not work so well for thick CCDs due to the surface bumps created by the surface electrodes.

Almost all Astronomical CCDs are Thinned and Backside Illuminated.

Quantum Efficiency Comparison

The graph below compares the quantum efficiency of a thick frontside illuminated CCD and a thin backside illuminated CCD.

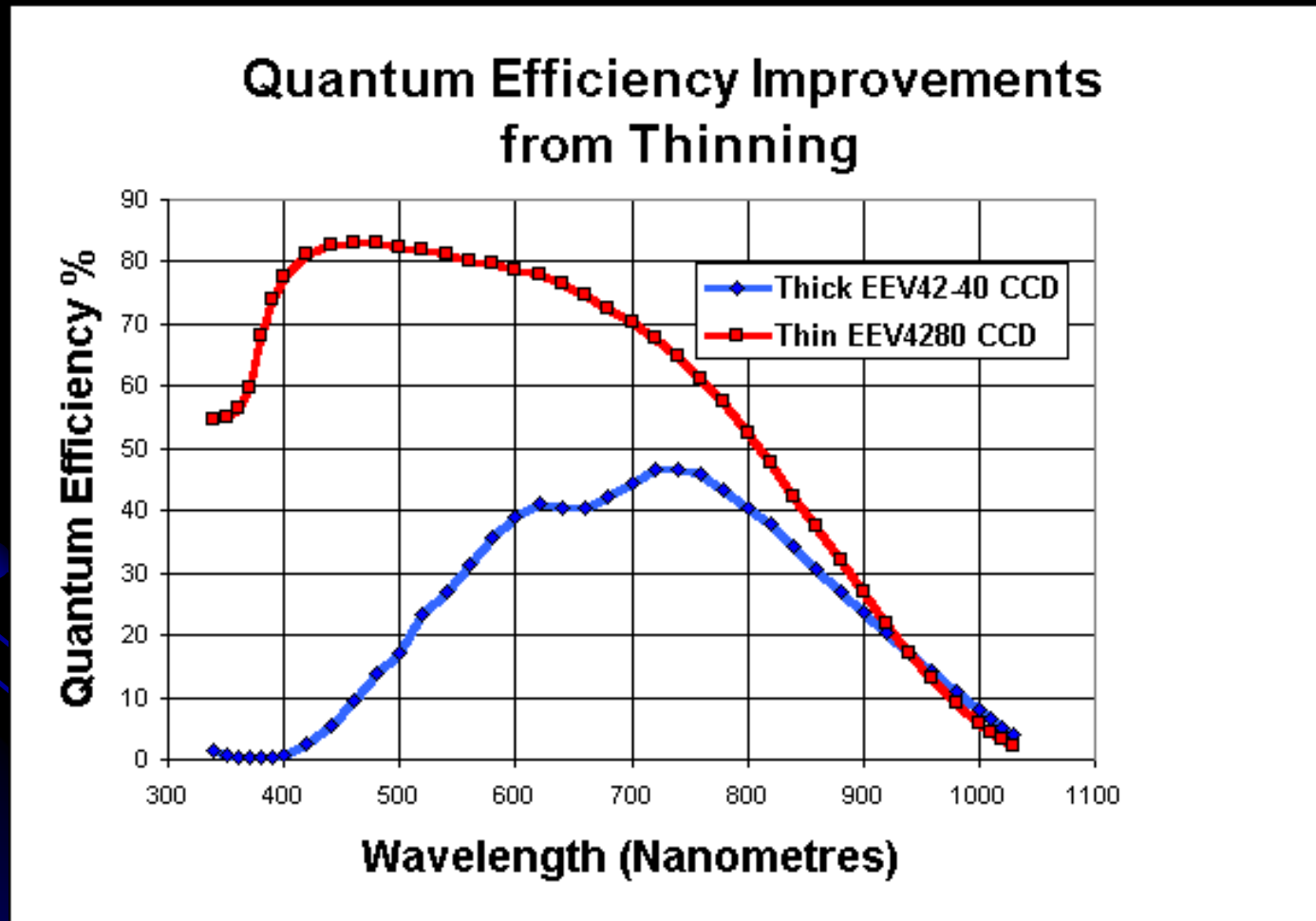

'Internal' Quantum Efficiency

If we take into account the reflectivity losses at the surface of a CCD we can produce a graph showing the 'internal QE' : the fraction of the photons that enter the CCDs bulk that actually produce a detected photo-electron. This fraction is remarkably high for a thinned CCD. For the EEV 42-80 CCD, shown below, it is greater than 85% across the full visible spectrum. Today's CCDs are very close to being ideal visible light detectors!

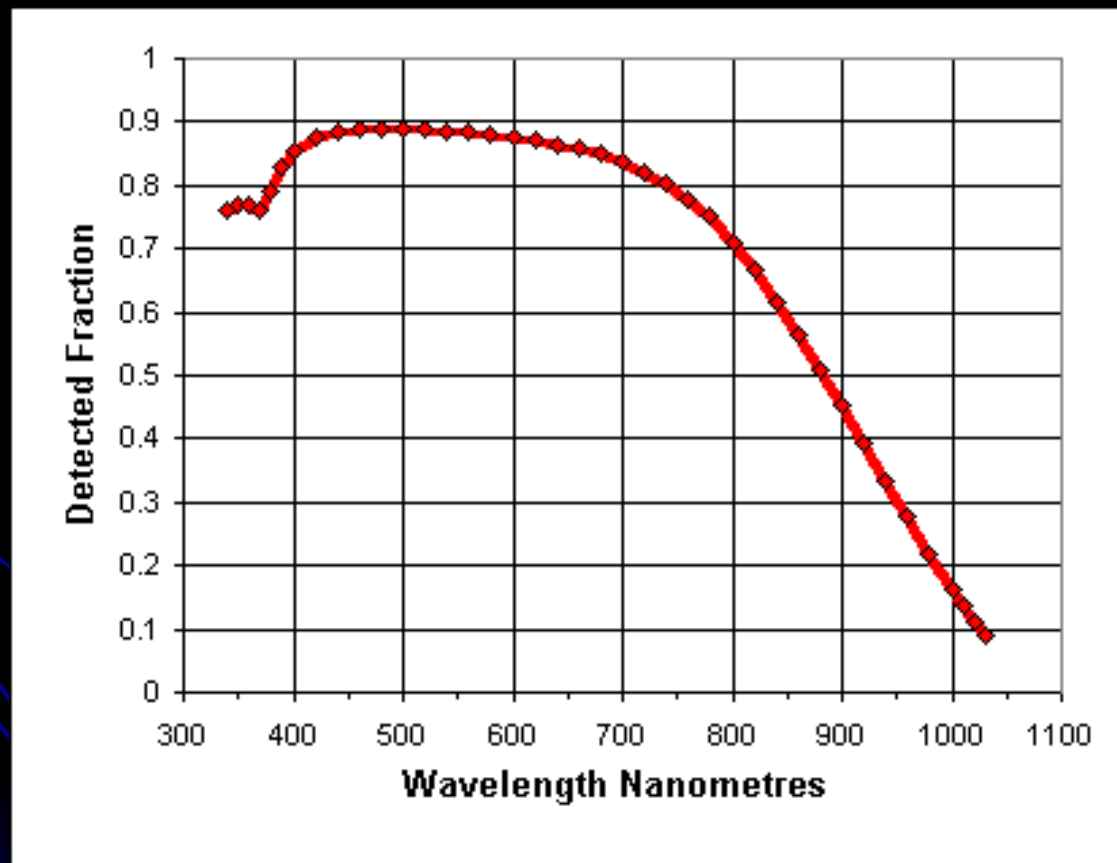

Appearance of CCDs

The fine surface electrode structure of a thick CCD is clearly visible as a multi-coloured interference pattern. Thinned Backside Illuminated CCDs have a much planer surface appearance. The other notable distinction is the two-fold (at least) price difference.

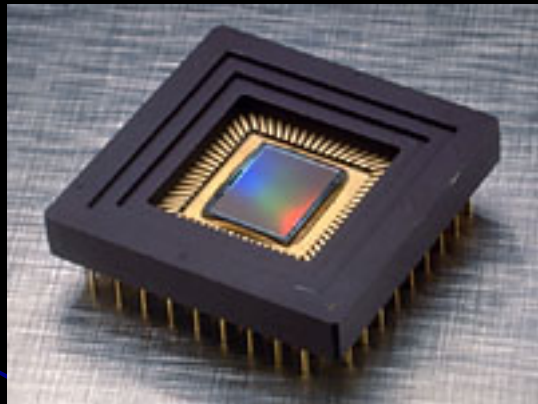

Kodak Kaf1401 Thick CCD

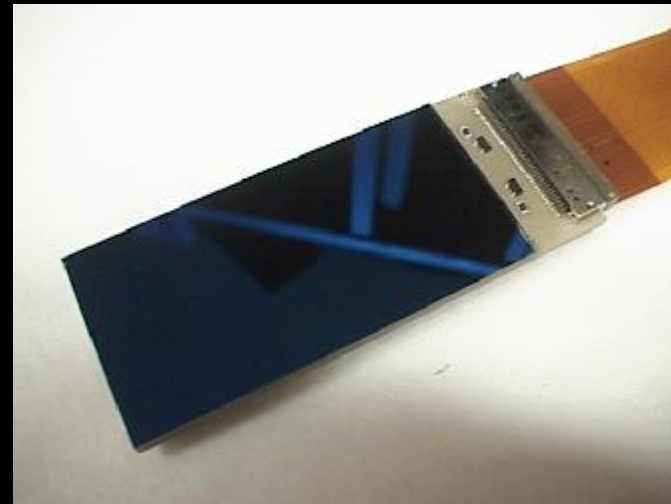

MIT/LL CC1D20 Thinned CCD

Blooming in a CCD 1.

The charge capacity of a CCD pixel is limited, when a pixel is full the charge starts to leak into adjacent pixels. This process is known as 'Blooming'.

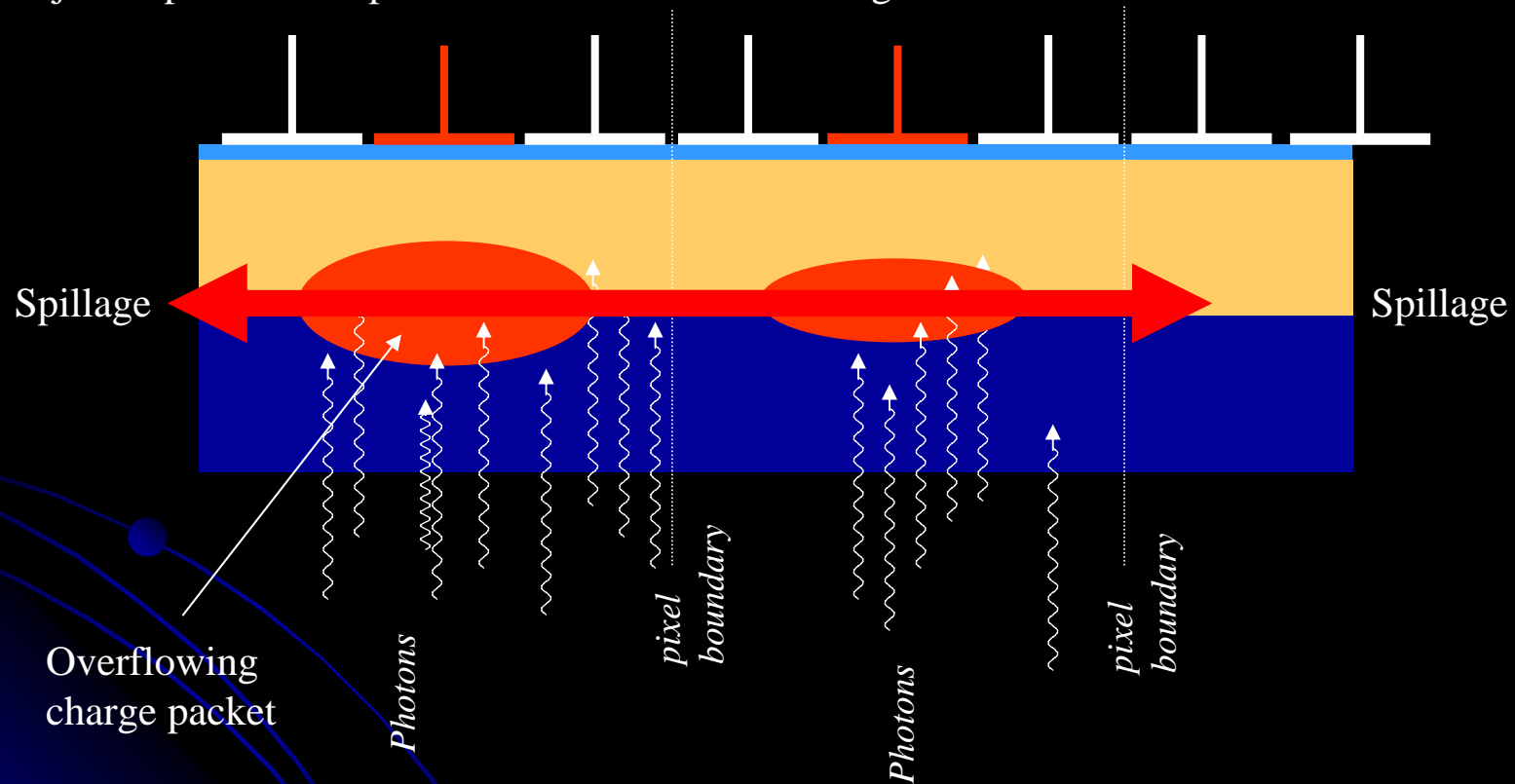

Blooming in a CCD 2.

The diagram shows one column of a CCD with an over-exposed stellar image focused on one pixel.

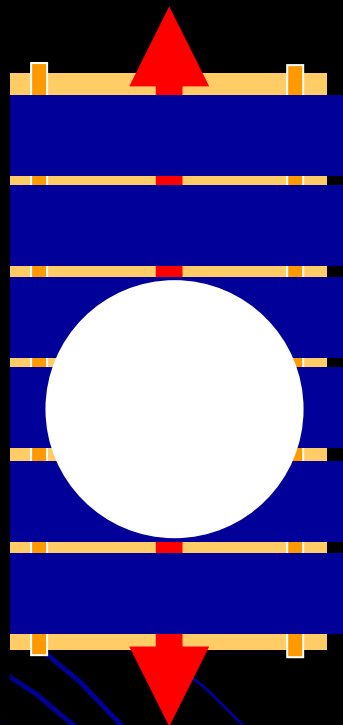

The channel stops shown in yellow prevent the charge spreading sideways. The charge confinement provided by the electrodes is less so the charge spreads vertically up and down a column.

The capacity of a CCD pixel is known as the 'Full Well'. It is dependent on the physical area of the pixel. For Tektronix CCDs, with pixels measuring $24\mu\text{m} \times 24\mu\text{m}$ it can be as much as 300,000 electrons. Bloomed images will be seen particularly on nights of good seeing where stellar images are more compact .

In reality, blooming is not a big problem for professional astronomy. For those interested in pictorial work, however, it can be a nuisance.

Blooming in a CCD 3.

The image below shows an extended source with bright embedded stars. Due to the long exposure required to bring out the nebulosity, the stellar images are highly overexposed and create bloomed images.

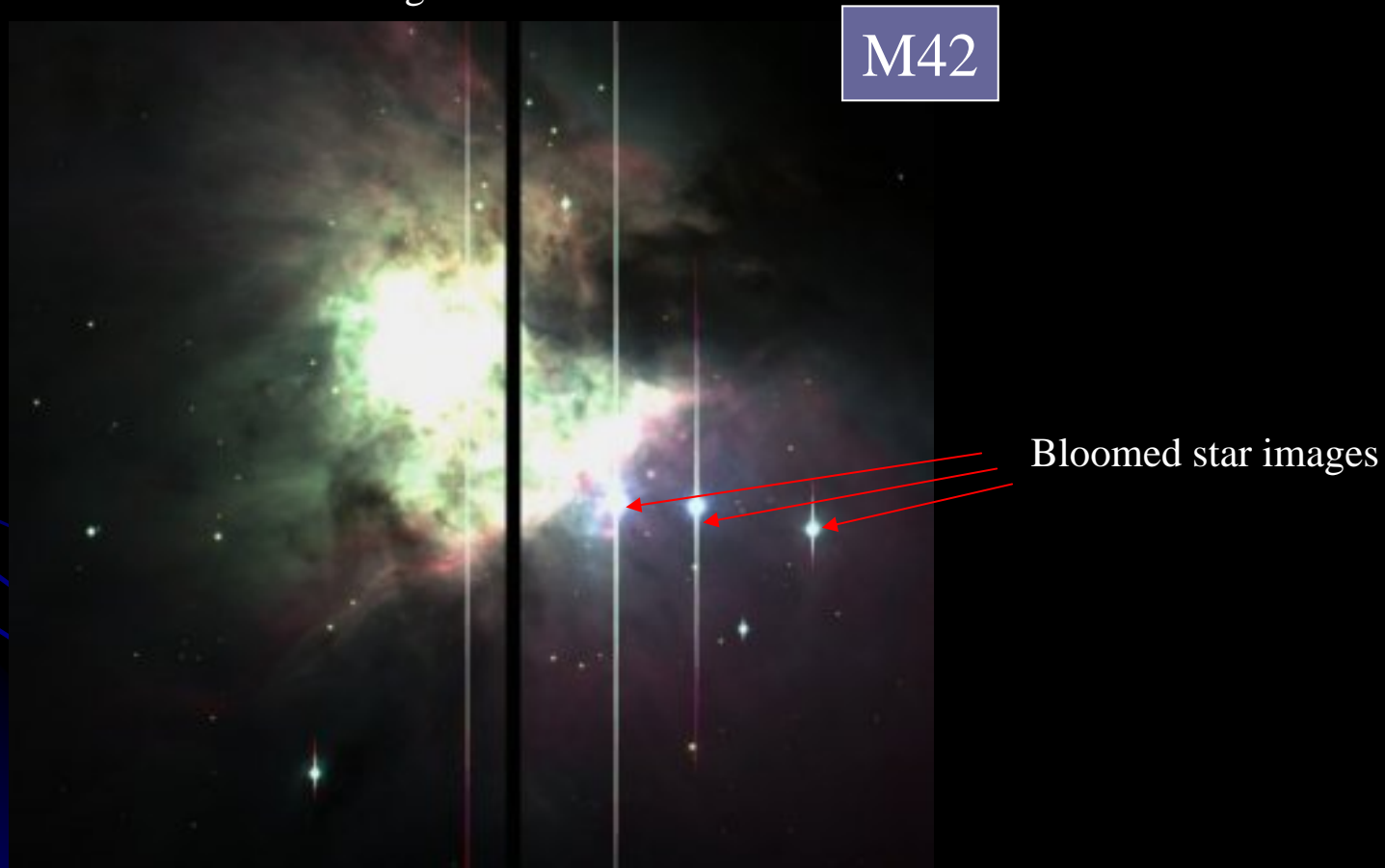

(The image is from a CCD mosaic and the black strip down the center is the space between adjacent detectors)

Image Defects in a CCD 1.

Unless one pays a huge amount it is generally difficult to obtain a CCD free of image defects. The first kind of defect is a 'dark column'. Their locations are identified from flat field exposures.



Dark columns are caused by 'traps' that block the vertical transfer of charge during image readout. The CCD shown at left has at least 7 dark columns, some grouped together in adjacent clusters.

Traps can be caused by crystal boundaries in the silicon of the CCD or by manufacturing defects.

Although they spoil the chip cosmetically, dark columns are not a big problem for astronomers. This chip has 2048 image columns so 7 bad columns represents a tiny loss of data.

Flat field exposure of an EEV42-80 CCD

Image Defects in a CCD 2.

There are three other common image defect types : Cosmic rays, Bright columns and Hot Spots. Their locations are shown in the image below which is a lengthy exposure taken in the dark (a 'Dark Frame')

Bright Column

Cluster of Hot Spots

Cosmic rays

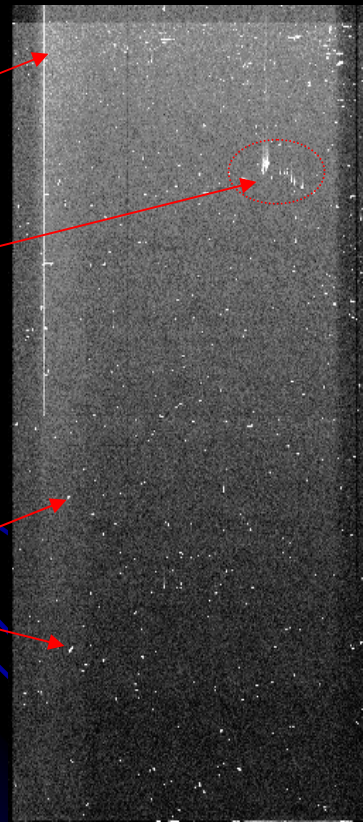

Bright columns are also caused by traps . Electrons contained in such traps can leak out during readout causing a vertical streak.

Hot Spots are pixels with higher than normal dark current. Their brightness increases linearly with exposure times

Cosmic rays are unavoidable. Charged particles from space or from radioactive traces in the material of the camera can cause ionisation in the silicon. The electrons produced are indistinguishable from photo-generated electrons.

Approximately 2 cosmic rays per cm^2 per minute will be seen. A typical event will be spread over a few adjacent pixels and contain several thousand electrons.

Somewhat rarer are light-emitting defects which are hot spots that act as tiny LEDs and cause a halo of light on the chip.

900s dark exposure of an EEV42-80 CCD

Image Defects in a CCD 3.

Some defects can arise from the processing electronics. This negative image has a bright line in the first image row.

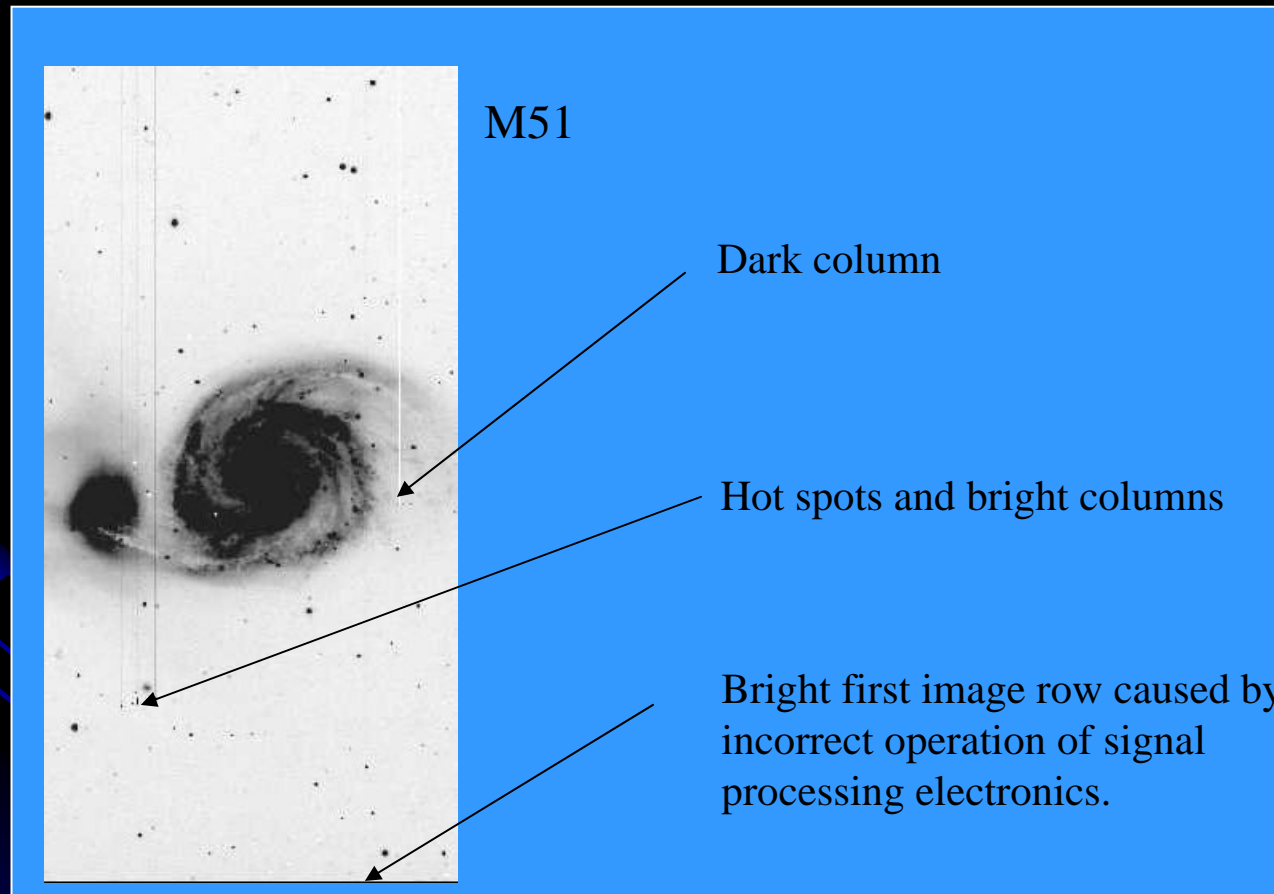

CCD calibration: Biases, Flat Fields and Dark Frames 1.

These are three types of calibration exposures that must be taken with a scientific CCD camera, generally before and after each observing session. They are stored alongside the science images and combined with them during image processing. These calibration exposures allow us to compensate for certain imperfections in the CCD. As much care needs to be exercised in obtaining these images as for the actual scientific exposures. Applying low quality flat fields and bias frames to scientific data can degrade rather than improve its quality.

Bias Frames

A bias frame is an exposure of zero duration taken with the camera shutter closed. It represents the zero point or base-line signal from the CCD. Rather than being completely flat and featureless the bias frame may contain some structure. Any bright image defects in the CCD will of course show up, there may be also slight gradients in the image caused by limitations in the signal processing electronics of the camera. It is normal to take about 5 bias frames before a night's observing. These are then combined using an image processing algorithm that averages the images, pixel by pixel, rejecting any pixel values that are appreciably different from the other 4. This can happen if a pixel in one bias frame is affected by a cosmic ray event. It is unlikely that the same pixel in the other 4 frames would be similarly affected so the resultant 'master bias', should be uncontaminated by cosmic rays. Taking a number of biases and then averaging them also reduces the amount of noise in the bias images. Averaging 5 frames will reduce the amount of read noise (electronic noise from the CCD amplifier) in the image by the square-root of 5.

Biases, Flat Fields and Dark Frames 2.

Flat Fields

Some pixels in a CCD will be more sensitive than others. In addition there may be dust spots on the surface of either the chip, the window of the camera or the coloured filters mounted in front of the camera. A star focused onto one part of a chip may therefore produce a lower signal than it might do elsewhere. These variations in sensitivity across the surface of the CCD must be calibrated out or they will add noise to the image. The way to do this is to take a 'flat-field' image: an image in which the CCD is evenly illuminated with light. Dividing the science image, pixel by pixel, by a flat field image will remove these sensitivity variations very effectively.

Since some of these variations are caused by shadowing from dust spots, it is important that the flat fields are taken shortly before or after the science exposures; the dust may move around! As with biases, it is normal to take several flat field frames and average them to produce a 'Master'.

A flat field is taken by pointing the telescope at an extended, evenly illuminated source. The twilight sky or the inside of the telescope dome are the usual choices. An exposure time is chosen that gives pixel values about halfway to their saturation level i.e. a medium level exposure.

Dark Frames.

Dark current is generally absent from professional cameras since they are operated cold using liquid nitrogen as a coolant. Amateur systems running at higher temperatures will have some dark current and its effect must be minimised by obtaining 'dark frames' at the beginning of the observing run. These are exposures with the same duration as the science frames but taken with the camera shutter closed. These are later subtracted from the science frames. Again, it is normal to take several dark frames and combine them to form a Master, using a technique that rejects cosmic ray features.

This is also commonly used with infrared detectors where dark signal is higher.

Biases, Flat Fields and Dark Frames 3.

A dark frame and a flat field from the same EEV42-80 CCD are shown below. The dark frame shows a number of bright defects on the chip. The flat field shows a criss-cross patterning on the chip created during manufacture and a slight loss of sensitivity in two corners of the image. Some dust spots are also visible.

Dark Frame

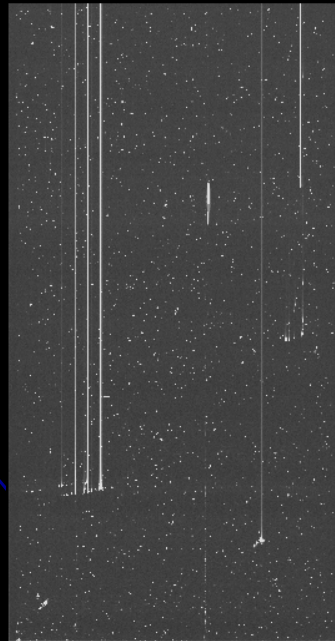

Flat Field

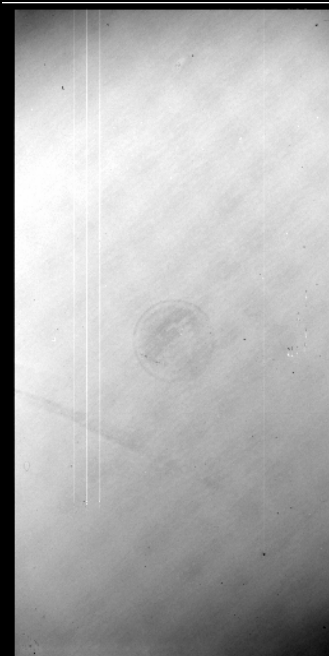

Biases, Flat Fields and Dark Frames 4. Image processing

If there is significant dark current present, the various calibration and science frames are combined by the following series of subtractions and divisions :

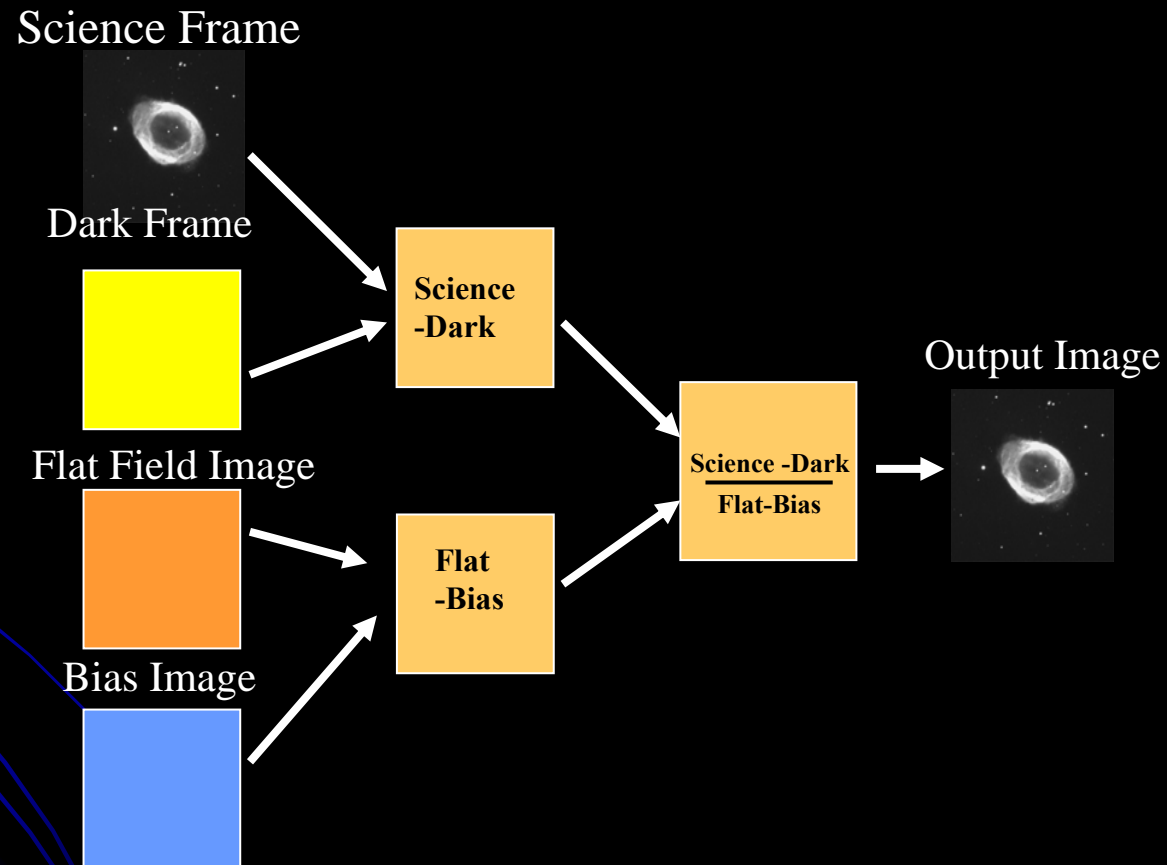

Dark Frames and Flat Fields 5. Image processing

In the absence of dark current, the process is slightly simpler :

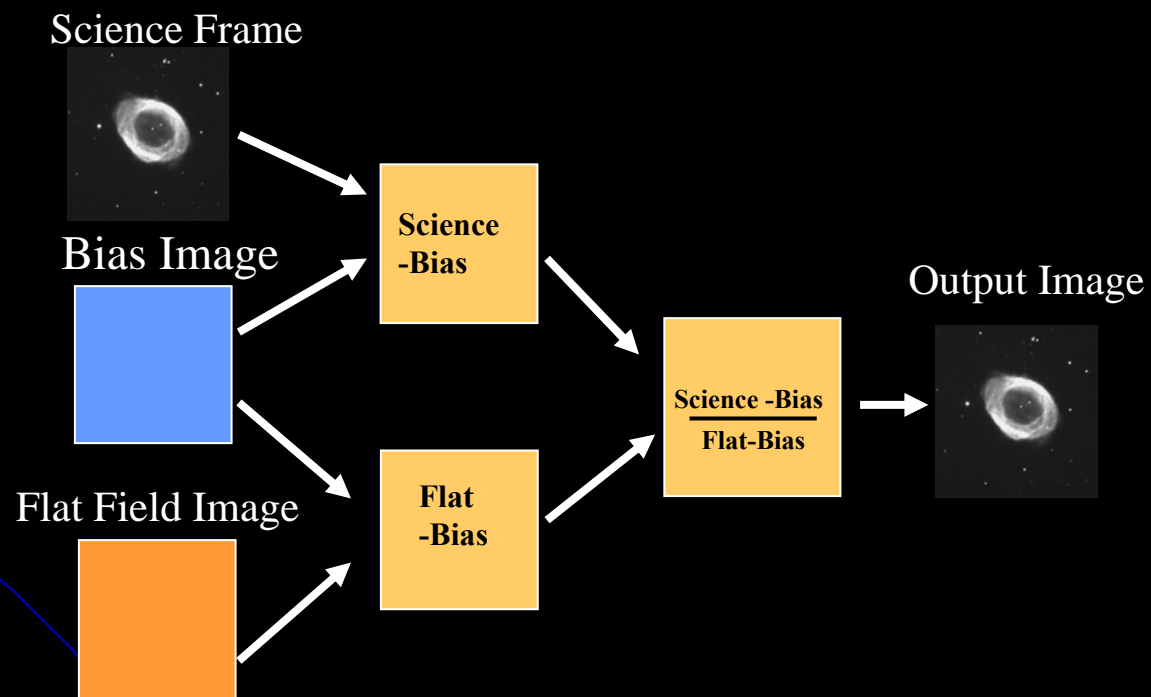

Pixel Size and Binning 1.

Nyquist Sampling

It is important to match the size of a CCD pixel to the focal length of the telescope. Atmospheric seeing places a limit on the sharpness of an astronomical image for telescope apertures above 15cm. Below this aperture, the images will be limited by diffraction effects in the optics. In excellent seeing conditions, a large telescope can produce stellar images with a diameter of 0.6 arc-seconds. In order to record all the information present in such an image, two pixels must fit across the stellar image; the pixels must subtend at most 0.3 arc-seconds on the sky. This is the 'Nyquist criteria'. If the pixels are larger than 0.3 arc-seconds the Nyquist criteria is not met, the image is under-sampled and information is lost. The Nyquist criteria also applies to the digitisation of audio waveforms. The audio bandwidth extends up to 20KHz, so the Analogue to Digital Conversion rate needs to exceed 40KHz for full reproduction of the waveform. Exceeding the Nyquist criteria leads to 'over-sampling'. This has the disadvantage of wasting silicon area; with improved matching of detector and optics a larger area of sky could be imaged.

Under-sampling an image can produce some interesting effects. One of these is the introduction of features that are not actually present. This is occasionally seen in TV broadcasts when, for example, the fine-patterned shirt of an interviewee breaks up into psychedelic bands and ripples. In this example, the TV camera pixels are too big to record the fine detail present in the shirt. This effect is known as 'aliasing'.

Pixel Size and Binning 2.

Matching the Pixels to the telescope

Example 1.

The William Herschel Telescope, with a 4.2m diameter primary mirror and a focal ratio of 3 is to be used for prime focus imaging. What is the optimum pixel size assuming that the best seeing at the telescope site is 0.7 arc-seconds ?

First we calculate the 'plate-scale' in arc-seconds per millimeter at the focal plane of the telescope.

$$\text{Plate Scale (arc-seconds per mm)} = \frac{206265}{\text{Aperture in mm} \times \text{f-number}} = 16.4 \text{ arc-sec per mm}$$

(Here the factor 206265 is the number of arc-seconds in a Radian)

Next we calculate the linear size at the telescope focal plane of a stellar image (in best seeing conditions)

$$\text{Linear size of stellar image} = 0.7 / \text{Plate Scale} = 0.7 / 16.4 = 42 \text{ microns. } 42/2 = 21, \text{ so:}$$

To satisfy the Nyquist criteria, the maximum pixel size is therefore 21 microns. In practice, the nearest pixel size available is 13.5 microns which leads to a small degree of over-sampling.

Pixel Size and Binning 4.

Binning

In the first example we showed that with 13.5micron pixels the system exceeded the Nyquist Criteria even on nights with exceptionally good sub-arcsecond seeing. If we now suppose that the seeing is 2 arc-seconds, the size of a stellar image will increase to 120microns on the detector. The image will now be grossly over-sampled. (One way to think of this is that the image is less sharp and therefore requires fewer pixels to record it). It would be more efficient now for the astronomer to switch to a detector with larger pixels since the resultant image files would be smaller, quicker to read out and would occupy less disc space.

There is a way to read out a CCD so as to increase the effective pixel size, this is known as 'Binning'. With binning we can increase pixel size arbitrarily. In the limit we could even read out the CCD as a single large pixel. Astronomers will more commonly use 2 x 2 binning which means that the charge in each 2 x 2 square of adjacent pixels is summed on the chip prior to delivery to the output amplifier. One important advantage of 'on-chip binning' is that it is a noise free process.

Binning is done in two distinct stages : vertical binning and horizontal binning. Each may be done without the other to yield rectangular pixels.

Pixel Size and Binning 5.

Stage 1 :Vertical Binning

This is done by summing the charge in consecutive rows .The summing is done in the serial register. In the case of 2 x 2 binning, two image rows will be clocked consecutively into the serial register prior to the serial register being read out. We now go back to the conveyor belt analogy of a CCD. In the following animation we see the bottom two image rows being binned.

● Charge packets

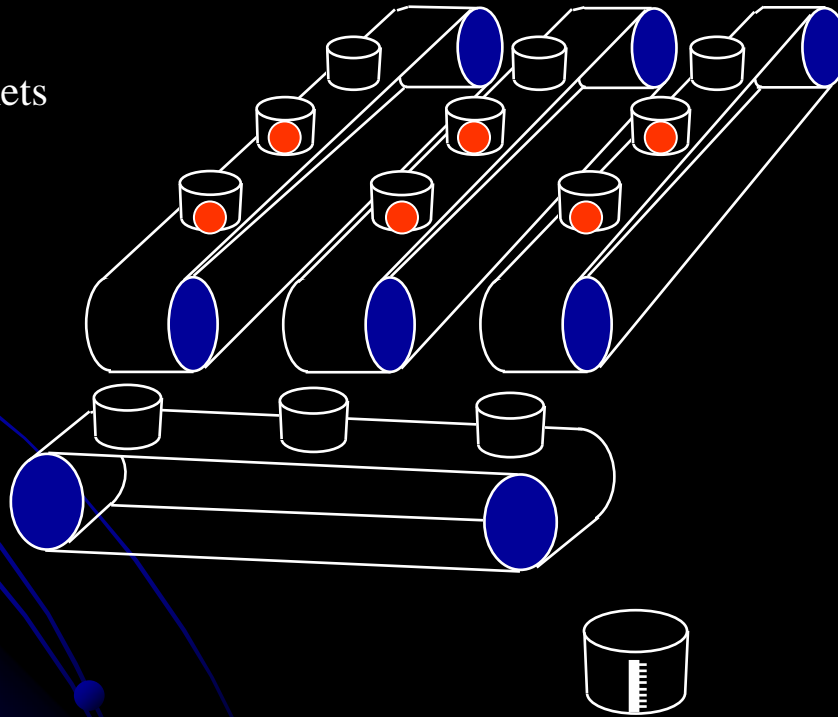

Pixel Size and Binning 6.

The first row is transferred into the serial register

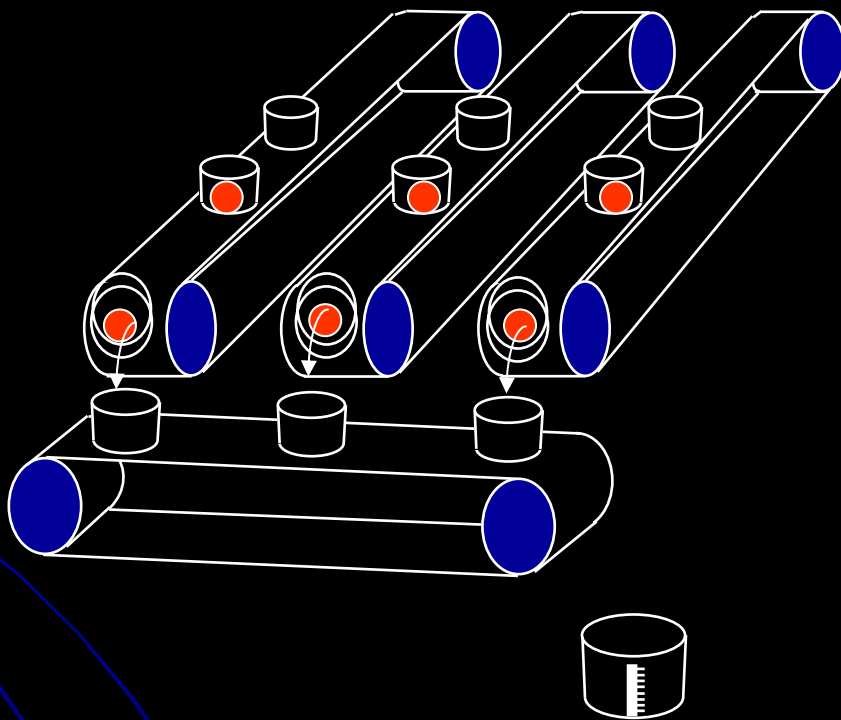

Pixel Size and Binning 7.

The serial register is kept stationary ready for the next row to be transferred.

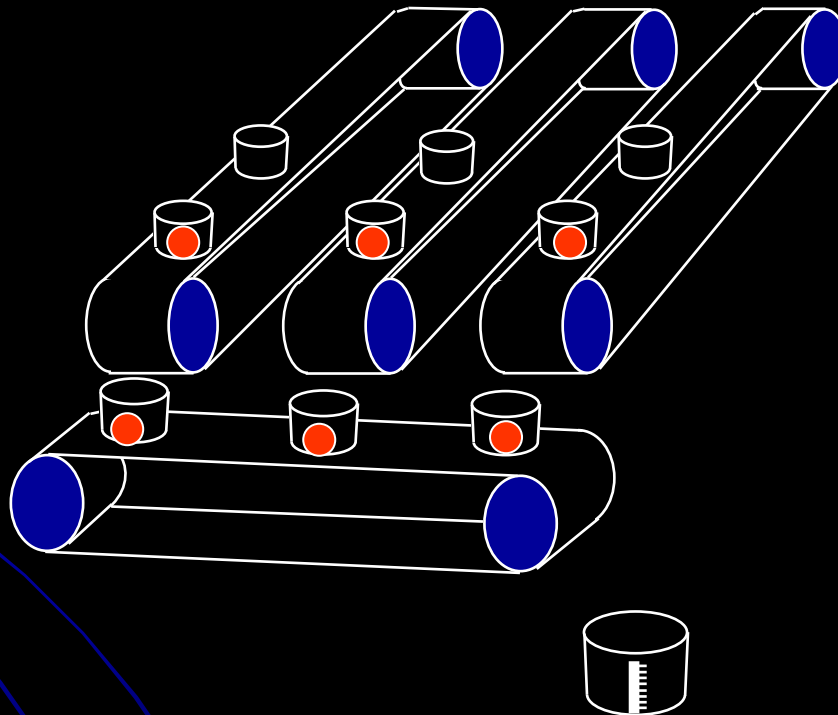

Pixel Size and Binning 8.

The second row is now transferred into the serial register.

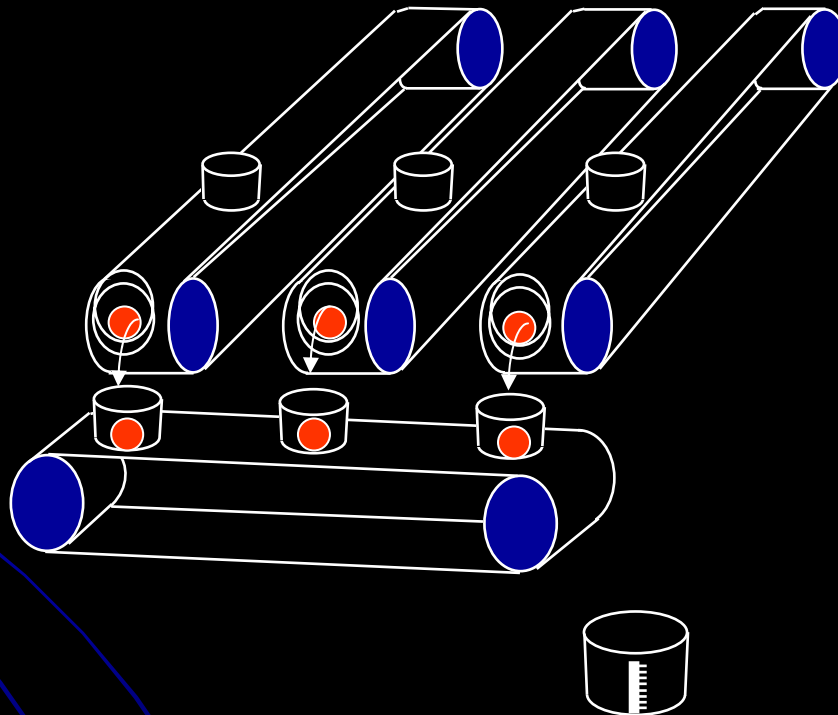

Pixel Size and Binning 9.

Each pixel in the serial register now contains the charge from two pixels in the image area. It is thus important that the serial register pixels have a higher charge capacity. This is achieved by giving them a larger physical size.

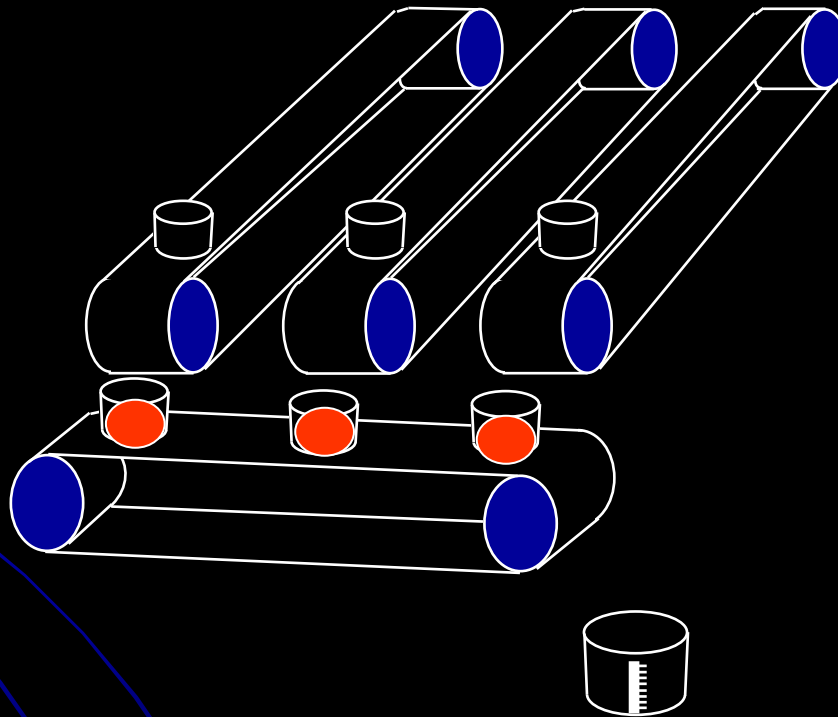

Pixel Size and Binning 10.

Stage 2 :Horizontal Binning

This is done by combining charge from consecutive pixels in the serial register on a special electrode positioned between serial register and the readout amplifier called the Summing Well (SW).

The animation below shows the last two pixels in the serial register being binned :

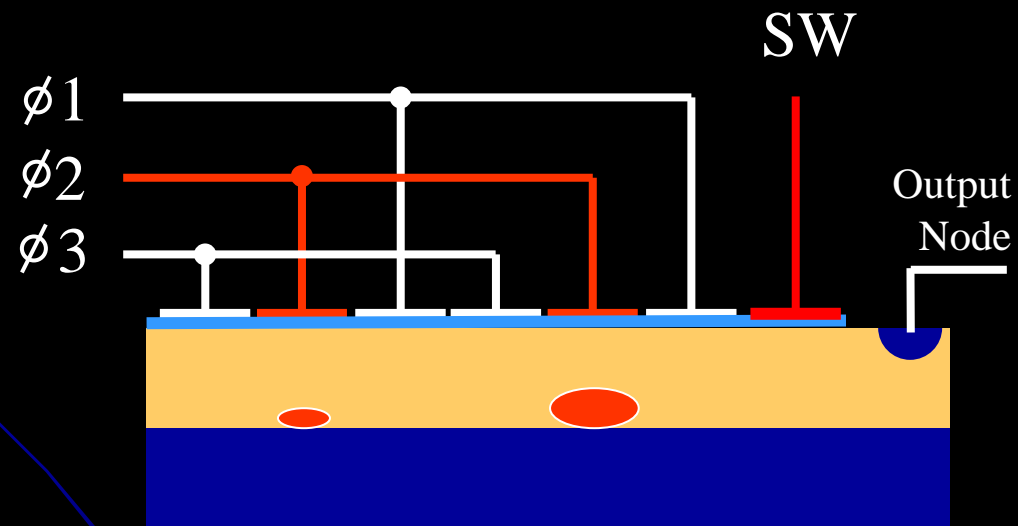

Pixel Size and Binning 11.

Charge is clocked horizontally with the SW held at a positive potential.

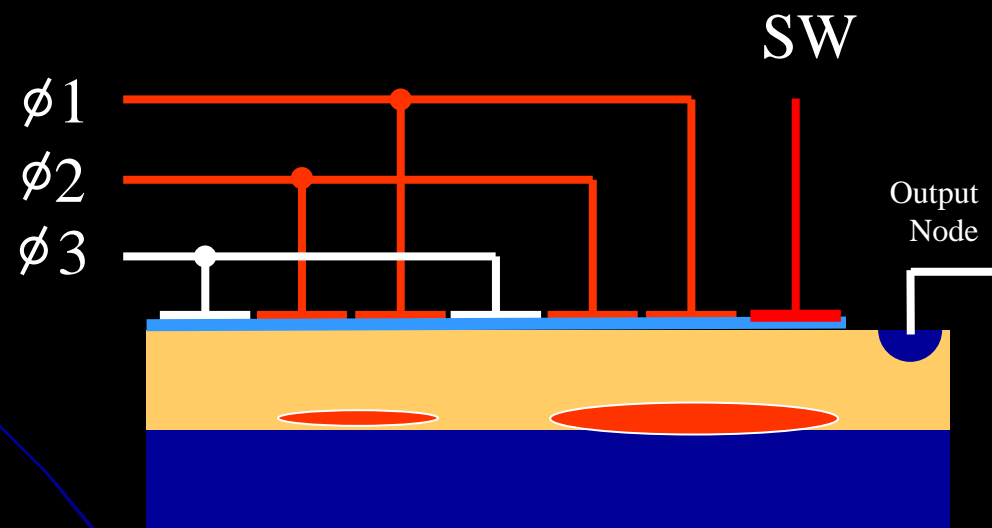

Pixel Size and Binning 12.

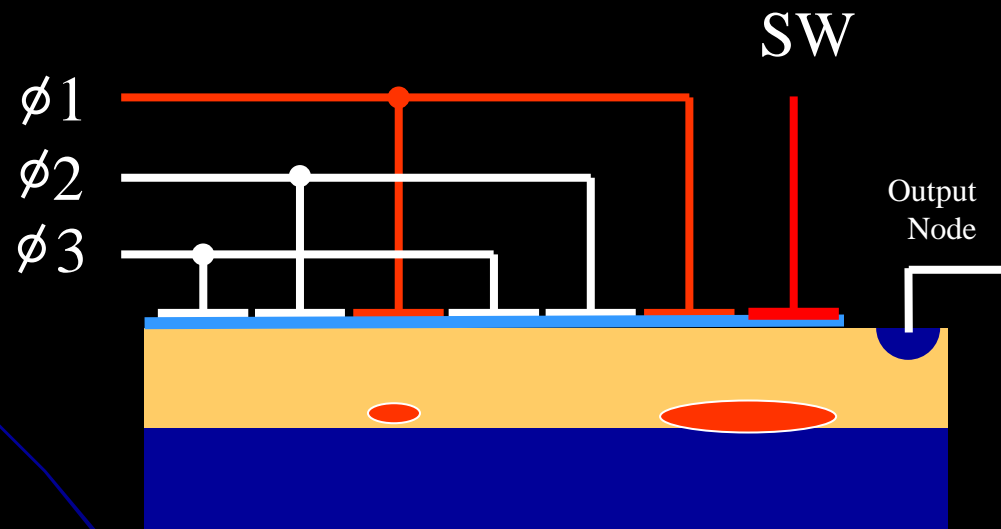

Pixel Size and Binning 13.

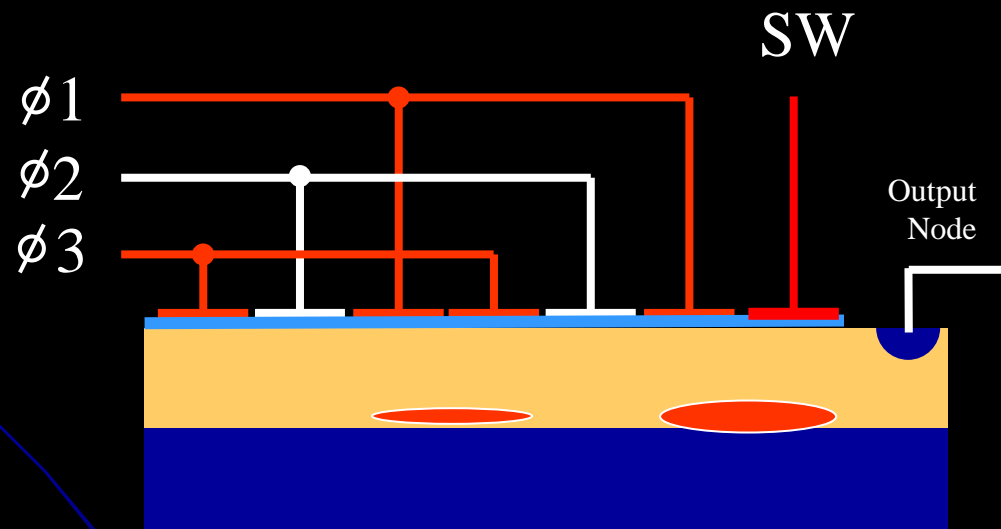

Pixel Size and Binning 14.

The charge from the first pixel is now stored on the summing well.

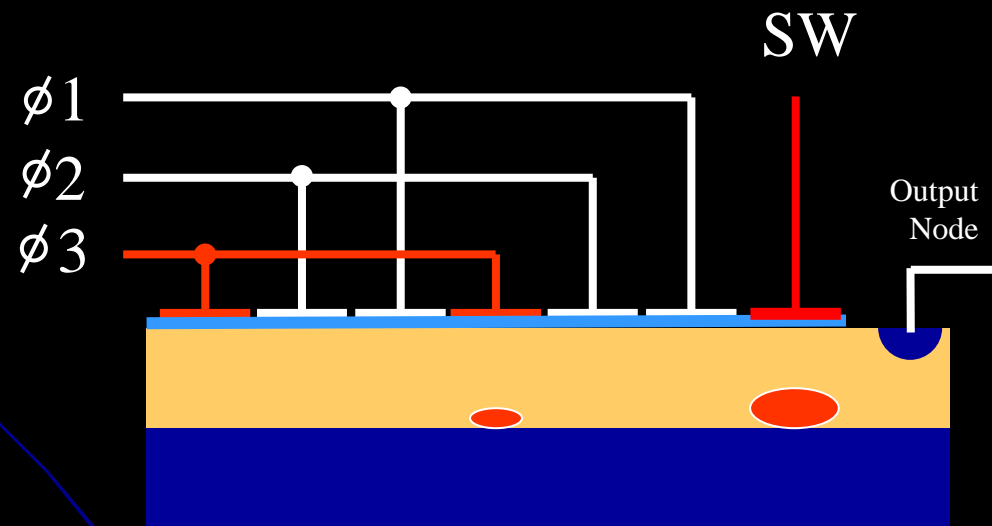

Pixel Size and Binning 15.

The serial register continues clocking.

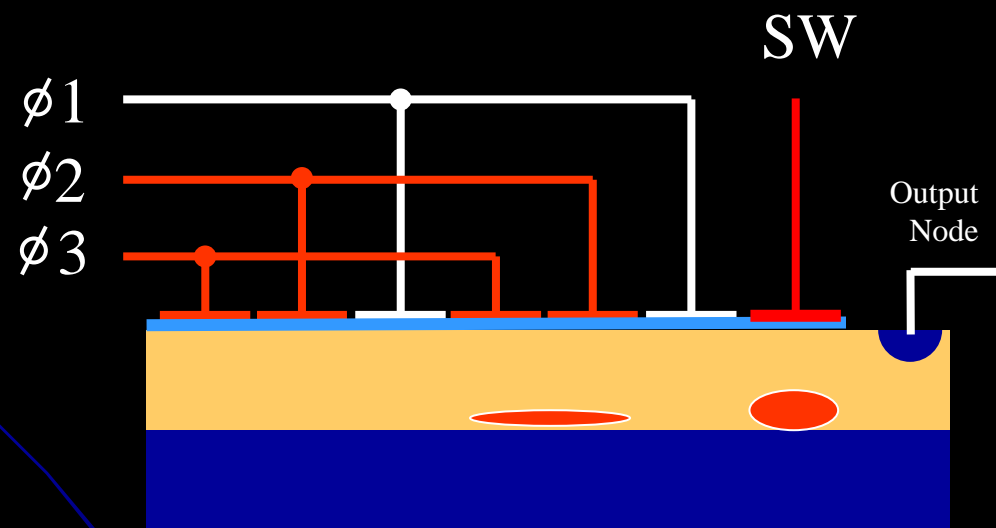

Pixel Size and Binning 16.

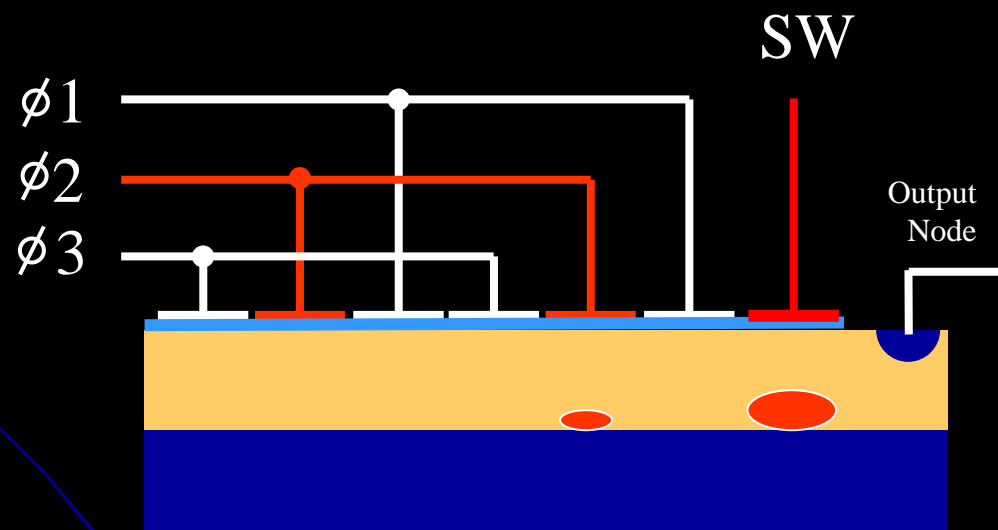

Pixel Size and Binning 17.

The SW potential is set slightly higher than the serial register electrodes.

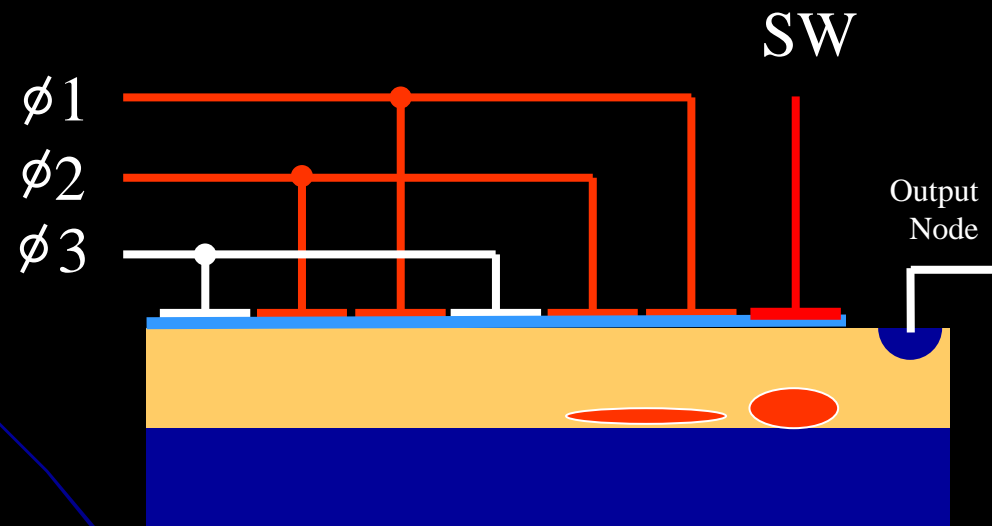

Pixel Size and Binning 18.

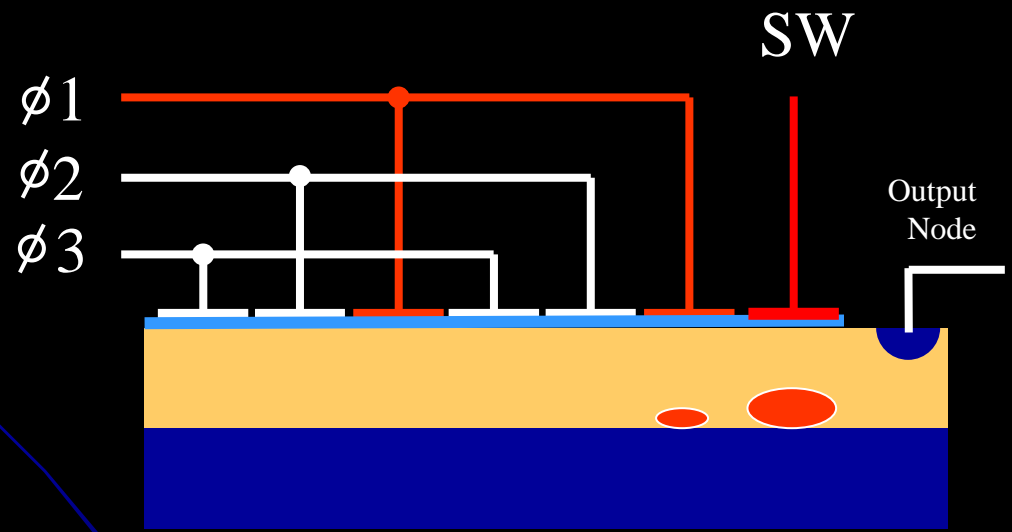

Pixel Size and Binning 19.

The charge from the second pixel is now transferred onto the SW. The binning is now complete and the combined charge packet can now be dumped onto the output node (by pulsing the voltage on SW low for a microsecond) for measurement.

Horizontal binning can also be done directly onto the output node if a SW is not present but this can increase the read noise.

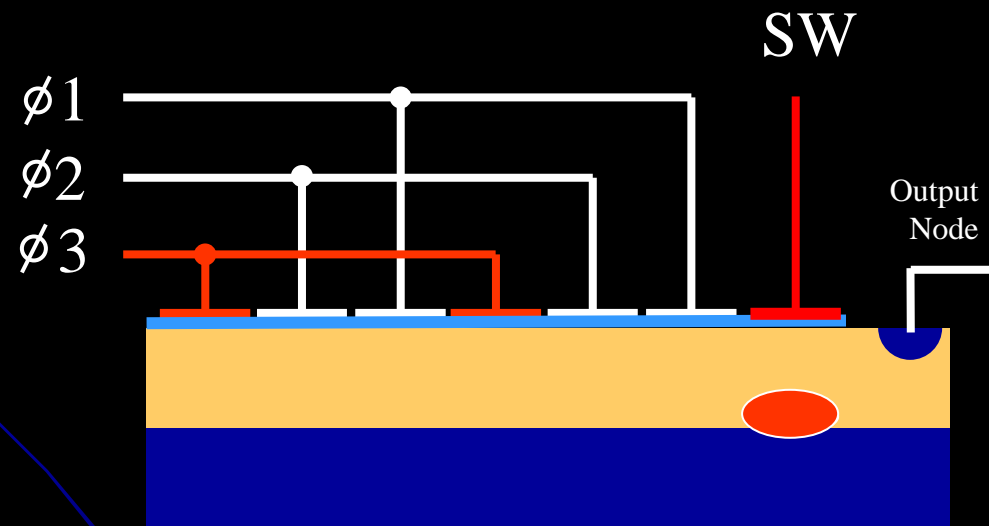

Pixel Size and Binning 20.

Finally the charge is dumped onto the output node for measurement

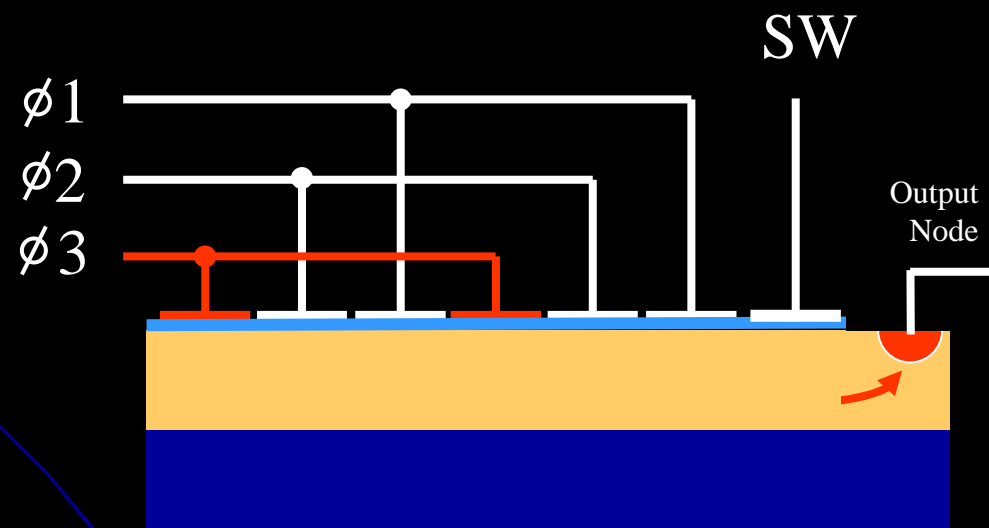

Chapter 3 : Advanced CCD Techniques.

In this activity some advanced topics in
CCD Imaging are explained.



Nik Szymanek

Integrating and Video CCD Cameras.

There is a difference in the geometry of an Integrating CCD camera compared to a Video CCD camera. An integrating camera, such as is used for most astronomical applications, is designed to stare at an object over an exposure time of many minutes. When readout commences and the charge is transferred out of the image area, line by line, into the serial register, the image area remains light sensitive. Since the readout can take as long as a minute, if there is no shutter, each stellar image will be drawn out into a line. An external shutter is thus essential to prevent smearing. These kind of CCDs are known as **'Slow Scan'**.

A video CCD camera is required to read out much more rapidly. A video CCD may be used by the astronomers as a finder-scope to locate objects of interest and ensure that the telescope is actually pointed at the target or it may be used for auto-guiding. These cameras must read out much more quickly, perhaps several times a second. A mechanical shutter operating at such frame rates could be unreliable. The geometry of a video CCD, however, incorporates a kind of electronic shutter on the CCD and no external shutter is required. These kind of CCDs are known as **'Frame Transfer'**.

Slow Scan CCDs 1.

The most basic geometry of a Slow-Scan CCD is shown below. Three clock lines control the three phases of electrodes in the image area, another three control those in the serial register. A single amplifier is located at the end of the serial register. The full image area is available for imaging. Because all the pixels are read through a single output, the readout speed is relatively low. The red line shows the flow of charge out of the CCD.

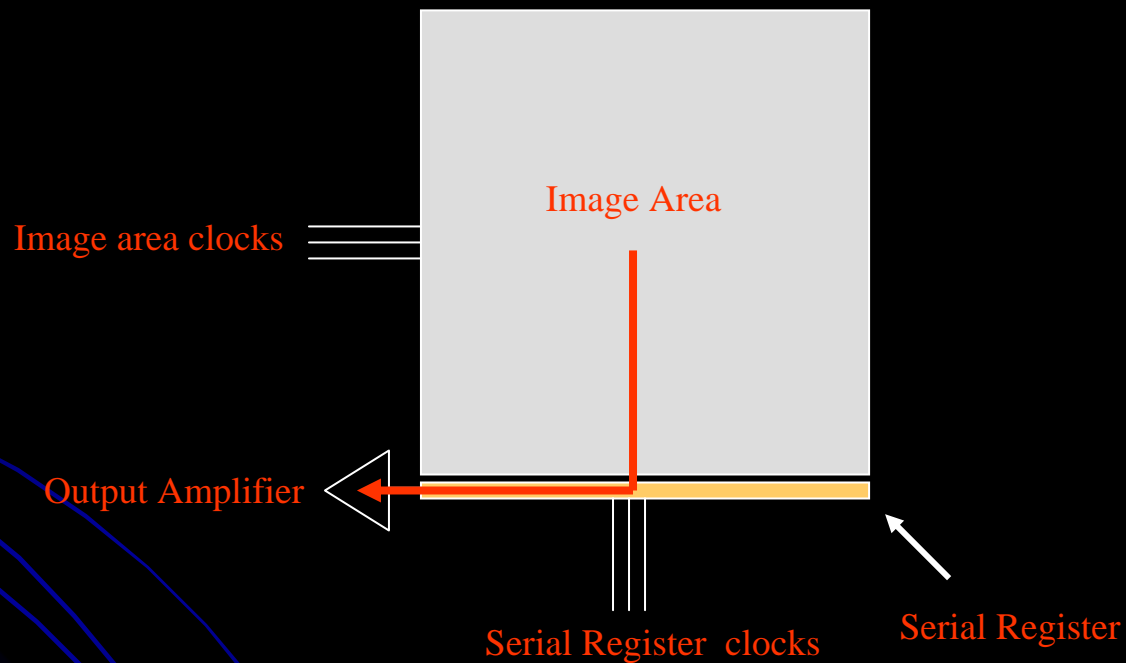

Slow Scan CCDs 2.

A slightly more complex design uses 2 serial registers and 4 output amplifiers. Extra clock lines are required to divide the image area into an upper and lower section. Further clock lines allow independent operation of each half of each serial register. It is thus possible to read out the image in four quadrants simultaneously, reducing the readout speed by a factor of four.

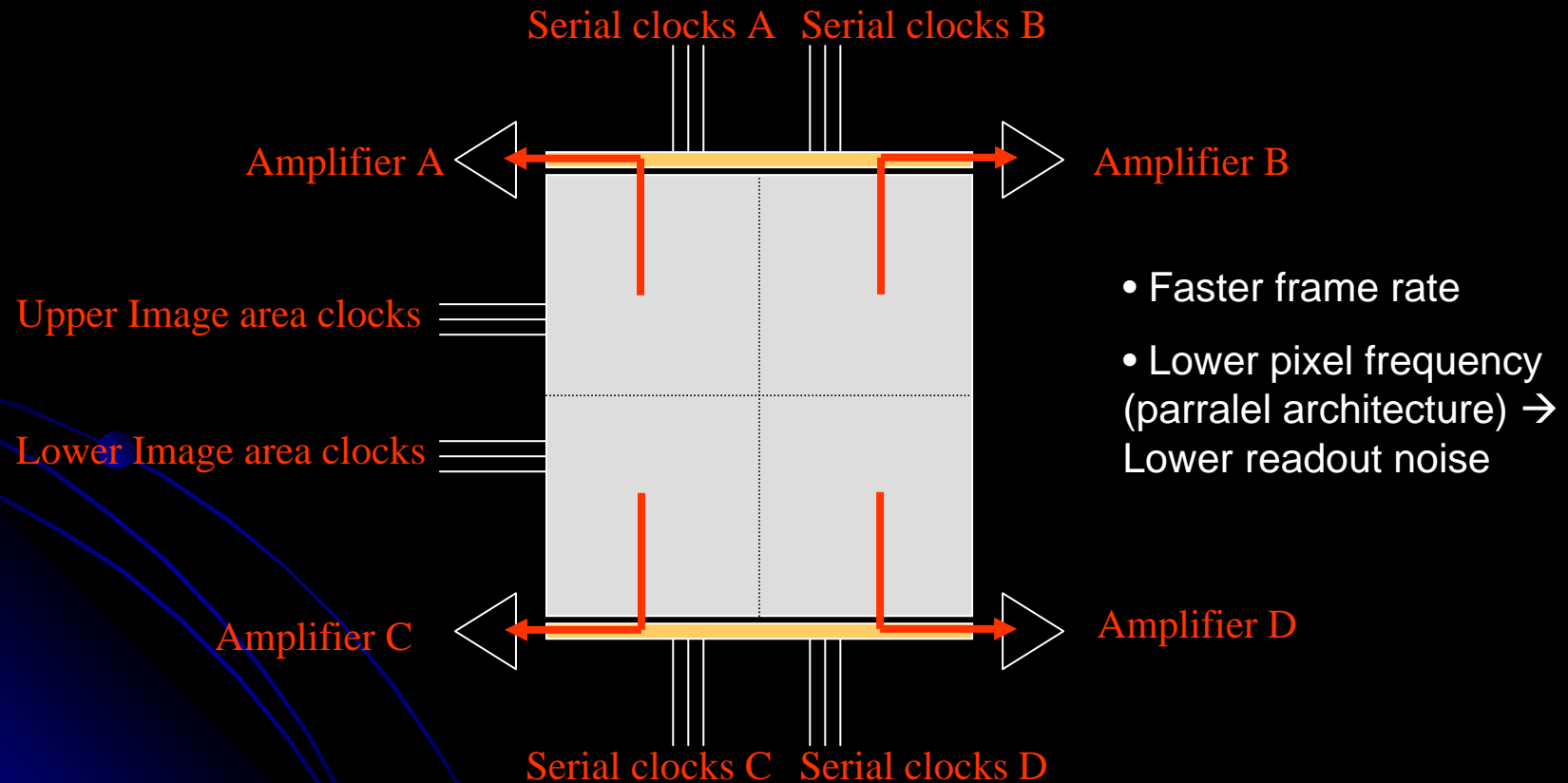

Slow Scan CCDs 3.

There are certain drawbacks to using this 'split-frame readout' method. The first is that each amplifier will have slightly different characteristics. It may have a slightly different gain or a differing linearity. Reconstructing a single image from the four sub-images can be an image processing nightmare and unless the application demands very high readout speed, most astronomers are content to wait slightly longer for an image read out through a single amplifier.

Another drawback is cost. CCDs that have all of their output amplifiers working are rare and come at a premium price.

Most CCDs are designed with multiple outputs. Even if only one of the working outputs is actually used, the others provide valuable backups should there be for any reason an amplifier failure.

Video CCDs 1.

In the split frame CCD geometry, the charge in each half of the image area could be shifted independently. Now imagine that the lower image area is covered with an opaque mask. This mask could be a layer of aluminium deposited on the CCD surface or it could be an external mask. This geometry is the basis of the 'Frame transfer' CCD that is used for high frame rate video applications. The area available for imaging is reduced by a half. The lower part of the image becomes the 'Store area'.

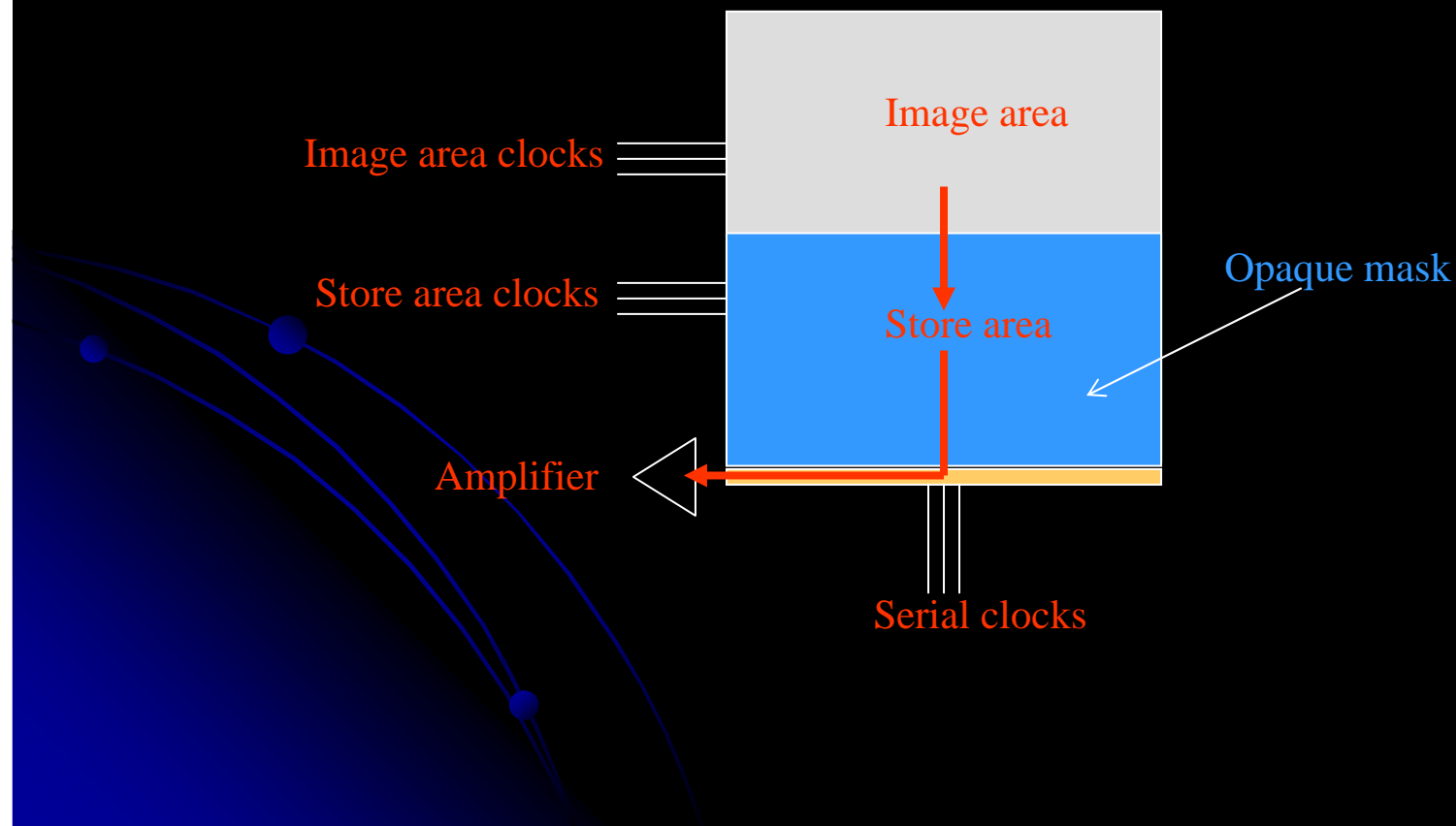

Video CCDs 2.

The operation of a Split Frame Video CCD begins with the integration of the image in the image area. Once the exposure is complete the charge in the image area is shifted down into the store area beneath the light proof mask. This shift is rapid; of the order of a few milliseconds for a large CCD. The amount of image smear that will occur in this time is minimal (remember there is no external shutter).

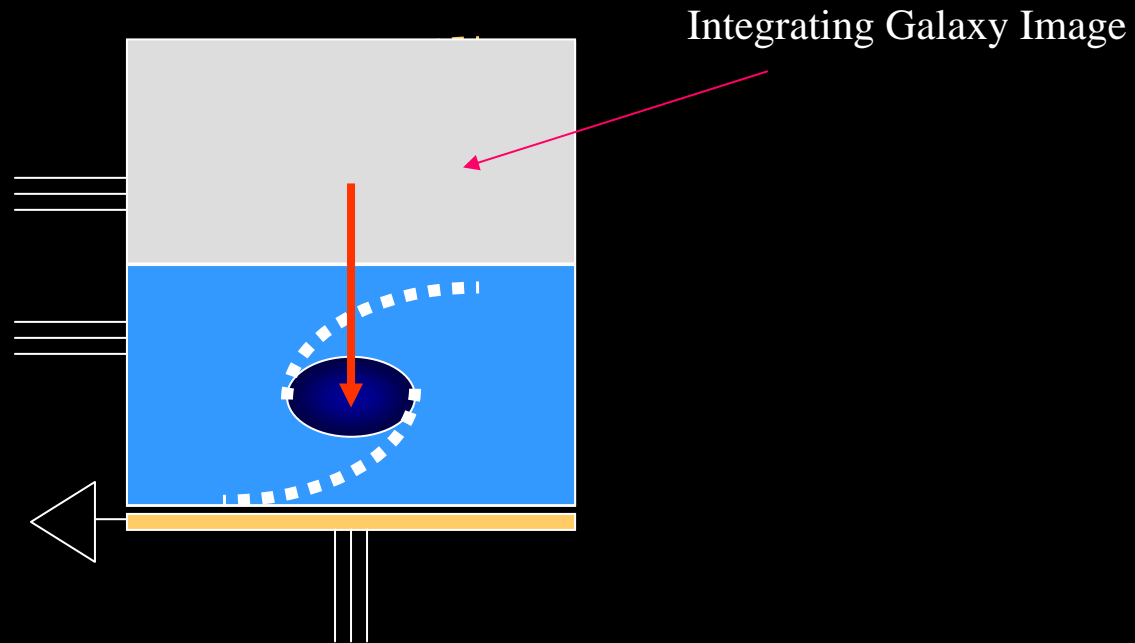

Video CCDs 3.

Once the image is safely stored under the mask, it can then be read out at leisure. Since we can independently control the clock phases in the image and store areas, the next image can be integrated in the image area during the readout. The image area can be kept continuously integrating and the detector has only a tiny 'dead time' during the image shift. No external shutter is required but the effective size of the CCD is cut by a half.

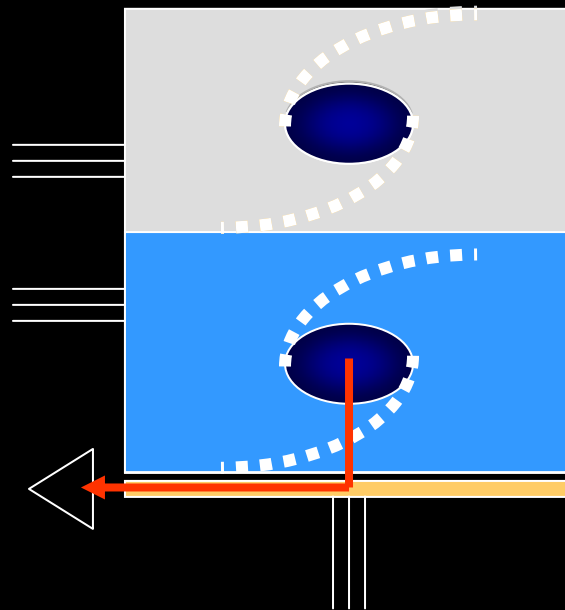

Correlated Double Sampler (CDS) 1.

The video waveform output by a CCD is at a fairly low level : every photo-electron in a pixel charge packet will produce a few micro-volts of signal. Additionally, the waveform is complex and precise timing is required to make sure that the correct parts are amplified and measured.

The CCD video waveform , as introduced in Chapter 1, is shown below for the period of one pixel measurement

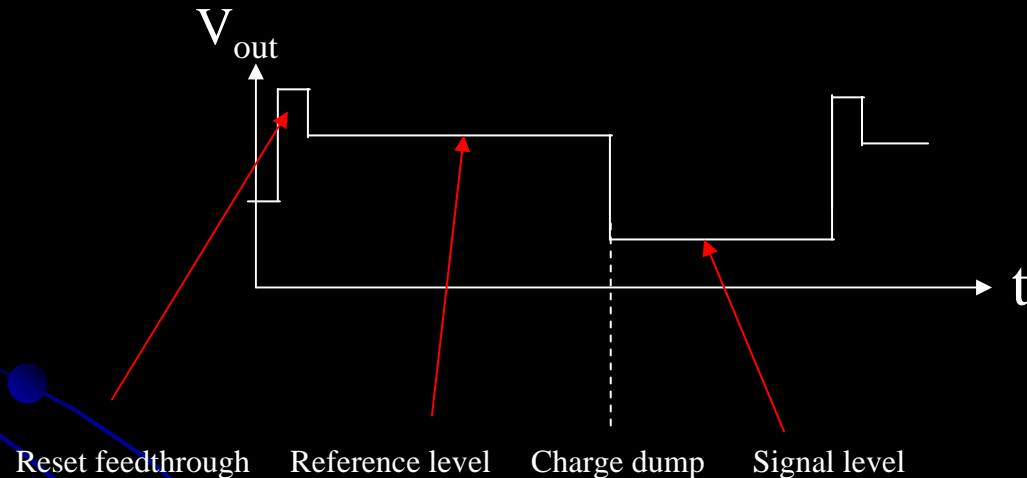

The video processor must measure , without introducing any additional noise, the Reference level and the Signal level. The first is then subtracted from the second to yield the output signal voltage proportional to the number of photo-electrons in the pixel under measurement. The best way to perform this processing is to use a ‘Correlated Double Sampler’ or CDS.

Correlated Double Sampler (CDS) 2.

The CDS design is shown schematically below. The CDS processes the video waveform and outputs a digital number proportional to the size of the charge packet contained in the pixel being read. There should only be a short cable length between CCD and CDS to minimise noise. The CDS minimises the read noise of the CCD by eliminating 'reset noise'. The CDS contains a high speed analogue processor containing computer controlled switches. Its output feeds into an Analogue to Digital Converter (ADC).

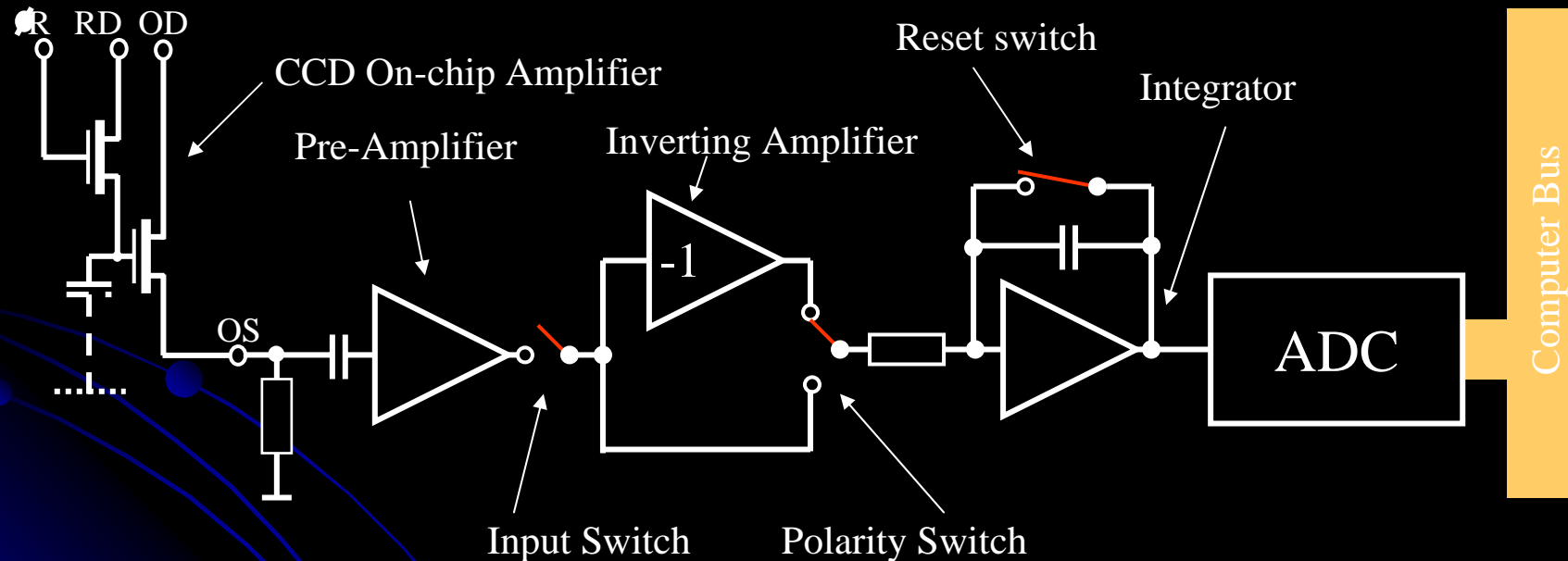

Correlated Double Sampler (CDS) 3.

The CDS starts work once the pixel charge packet is in the CCD summing well and the CCD reset pulse has just finished. At point t_0 the CCD wave-form is still affected by the reset pulse and so the CDS remains disconnected from the CCD to prevent this disturbing the video processor.

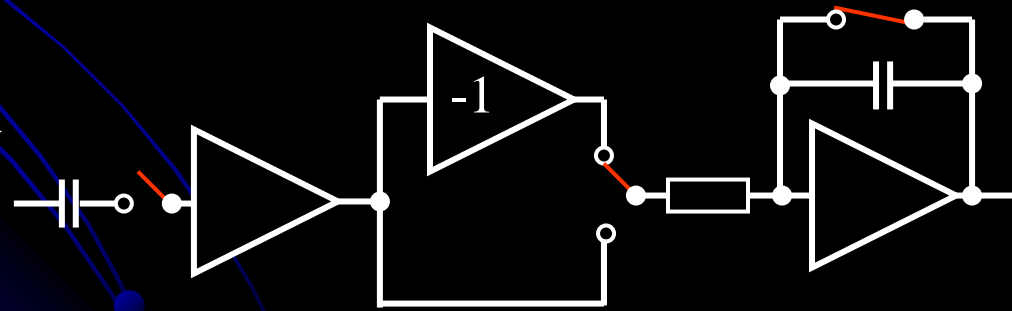
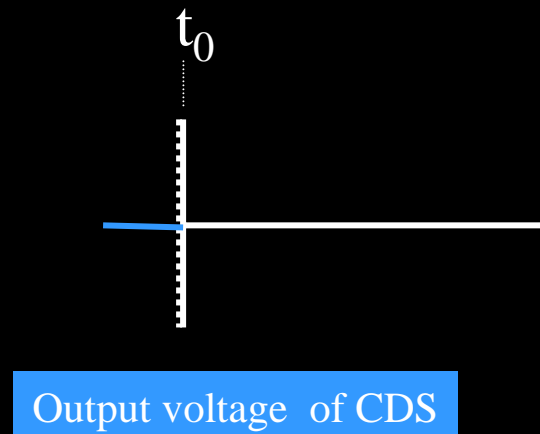
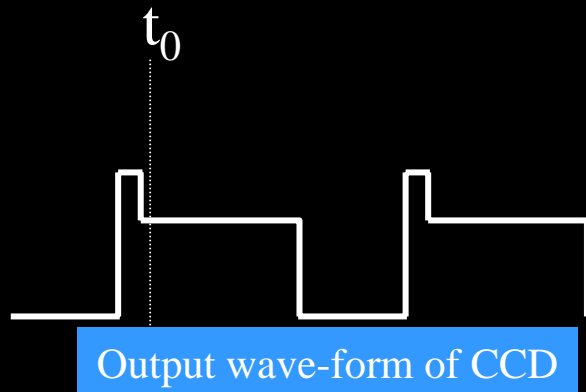

Correlated Double Sampler (CDS) 4.

Between t_1 and t_2 the CDS is connected and the 'Reference' part of the waveform is sampled. Simultaneously the integrator reset switch is opened and the output starts to ramp down linearly.

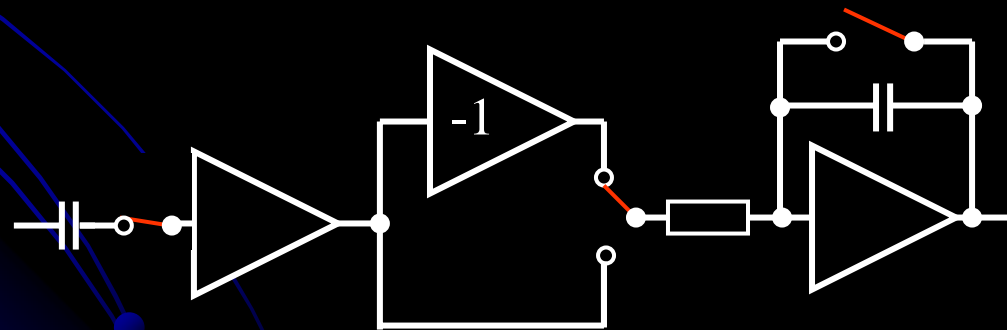
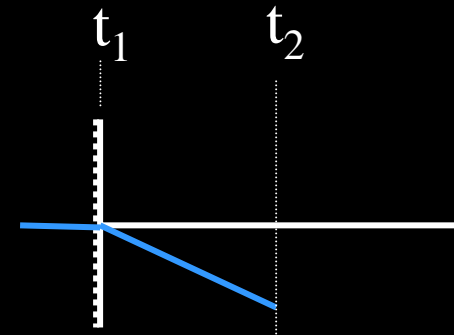
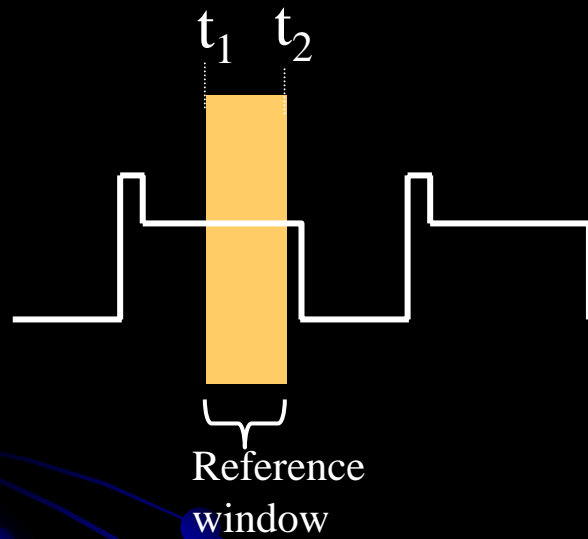

Correlated Double Sampler (CDS) 5.

Between t_2 and t_3 the 'charge dump' occurs in the CCD. The CCD output steps negatively by an amount proportional to the charge contained in the pixel. During this time the CDS is disconnected.

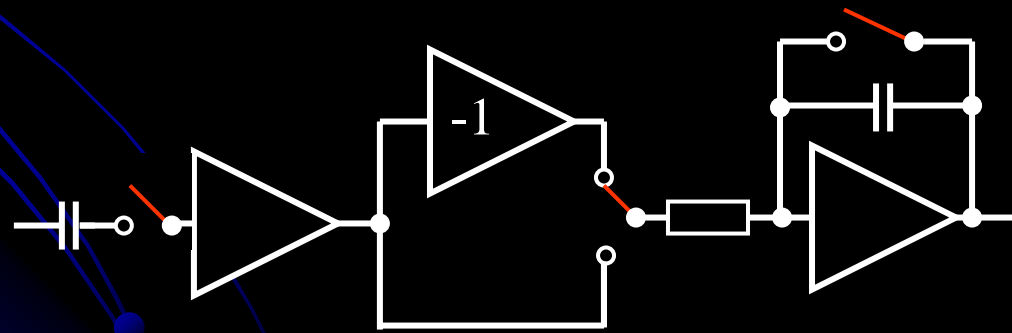

Correlated Double Sampler (CDS) 6.

Between t_3 and t_4 the CDS is reconnected and the 'signal' part of the wave-form is sampled. The input to the integrator is also 'polarity switched' so that the CDS output starts to ramp-up linearly. The width of the signal and sample windows must be the same. For Scientific CCDs this can be anything between 1 and 20 microseconds. Longer widths generally give lower noise but of course increase the read-out time.

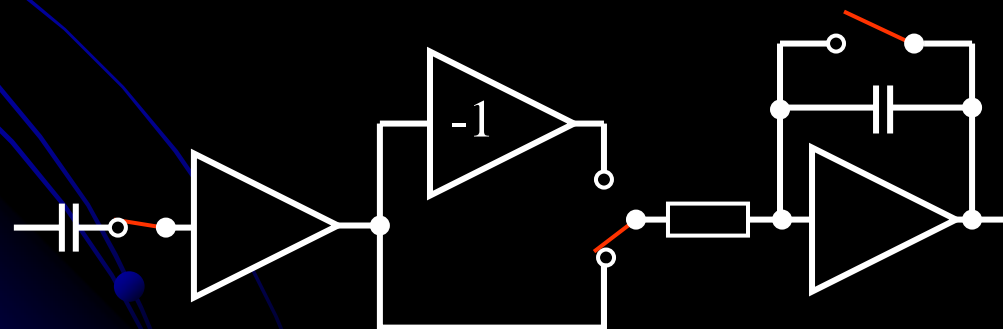
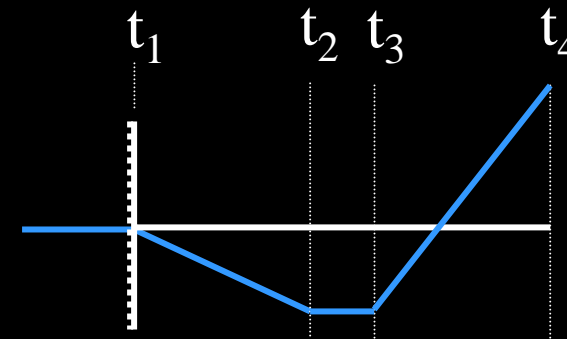
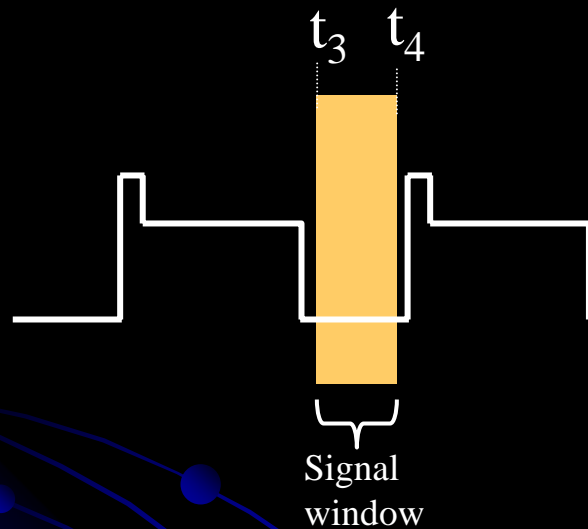

Correlated Double Sampler (CDS) 7.

The CDS is then once again disconnected and its output digitised by the ADC. This number, typically a 16 bit number (with a value between 0 and 65535) is then stored in the computer memory. The CDS then starts the whole process again on the next pixel. The integrator output is first zeroed by closing the reset switch. To process each pixel can take between a fraction of a microsecond for a TV rate CCD and several tens of microseconds for a low noise scientific CCD.

The type of CDS is called a 'dual slope integrator'. A simpler type of CDS known as a 'clamp and sample' only samples the waveform once for each pixel. It works well at higher pixel rates but is noisier than the dual slope integrator at lower pixel rates.

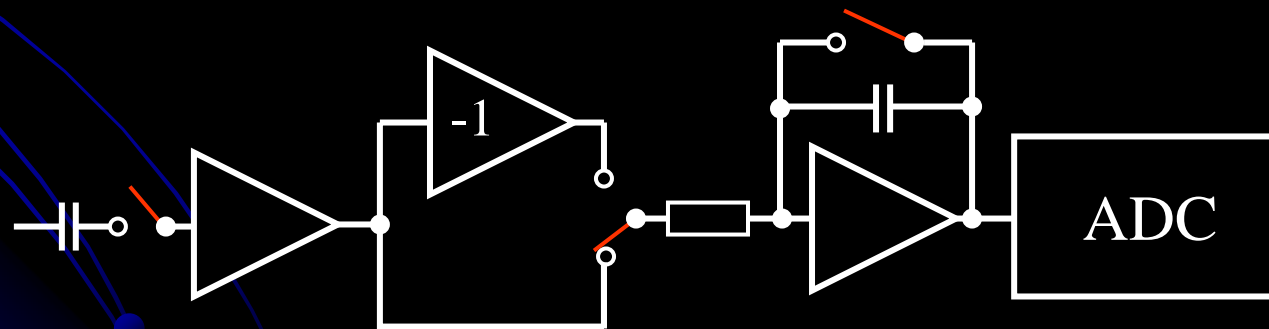
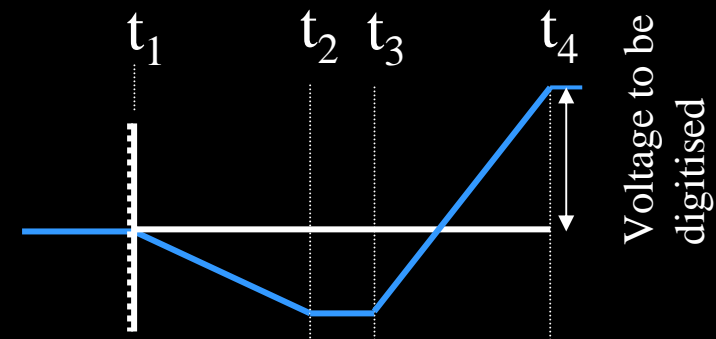

Noise Sources in a CCD Image 1.

The main noise sources found in a CCD are :

1. READ NOISE.

Caused by electronic noise in the CCD output transistor and possibly also in the external circuitry. Read noise places a fundamental limit on the performance of a CCD. It can be reduced at the expense of increased read out time. Scientific CCDs have a readout noise of 2-3 electrons RMS.

2. DARK CURRENT.

Caused by thermally generated electrons in the CCD. Eliminated by cooling the CCD.

3. PHOTON NOISE.

Also called 'Shot Noise'. It is due to the fact that the CCD detects photons. Photons arrive in an unpredictable fashion described by Poissonian statistics. This unpredictability causes noise.

4. PIXEL RESPONSE NON-UNIFORMITY.

Defects in the silicon and small manufacturing defects can cause some pixels to have a higher sensitivity than their neighbours. This noise source can be removed by 'Flat Fielding'; an image processing technique.

Noise Sources in a CCD Image 2.

Before these noise sources are explained further some new terms need to be introduced.

FLAT FIELDING

This involves exposing the CCD to a very uniform light source that produces a featureless and even exposure across the full area of the chip. A flat field image can be obtained by exposing on a twilight sky or on an illuminated white surface held close to the telescope aperture (for example the inside of the dome). Flat field exposures are essential for the reduction of astronomical data.

BIAS REGIONS

A bias region is an area of a CCD that is not sensitive to light. The value of pixels in a bias region is determined by the signal processing electronics. It constitutes the zero-signal level of the CCD.

The bias region pixels are subject only to readout noise. Bias regions can be produced by 'over-scanning' a CCD, i.e. reading out more pixels than are actually present. Designing a CCD with a serial register longer than the width of the image area will also create vertical bias strips at the left and right sides of the image. These strips are known as the 'x-underscan' and 'x-overscan' regions

A flat field image containing bias regions can yield valuable information not only on the various noise sources present in the CCD but also about the gain of the signal processing electronics i.e. the number of photoelectrons represented by each digital unit (ADU) output by the camera's Analogue to Digital Converter.

Noise Sources in a CCD Image 3.

Flat field images obtained from two CCD geometries are represented below. The arrows represent the position of the readout amplifier and the thick black line at the bottom of each image represents the serial register.

CCD With Serial Register equal in length to the image area width.



Here, the CCD is over-scanned in X and Y

CCD With Serial Register greater in length than the image area width.

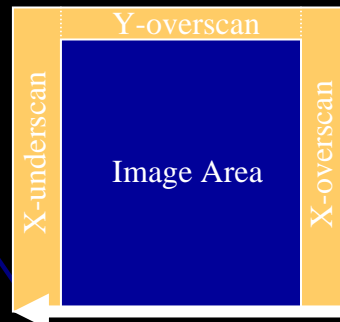

Here, the CCD is over-scanned in Y to produce the Y-overscan bias area. The X-underscan and X-overscan are created by extensions to the serial register on either side of the image area. When charge is transferred from the image area into the serial register, these extensions do not receive any photo-charge.

Noise Sources in a CCD Image 4.

These four noise sources are now explained in more detail:

READ NOISE.

This is mainly caused by thermally induced motions of electrons in the output amplifier. These cause small noise voltages to appear on the output. This noise source, known as Johnson Noise, can be reduced by cooling the output amplifier or by decreasing its electronic bandwidth. Decreasing the bandwidth means that we must take longer to measure the charge in each pixel, so there is always a trade-off between low noise performance and speed of readout. Mains pickup and interference from circuitry in the observatory can also contribute to Read Noise but can be eliminated by careful design. Johnson noise is more fundamental and is always present to some degree.

The graph below shows the trade-off between noise and readout speed for an EEV4280 CCD.

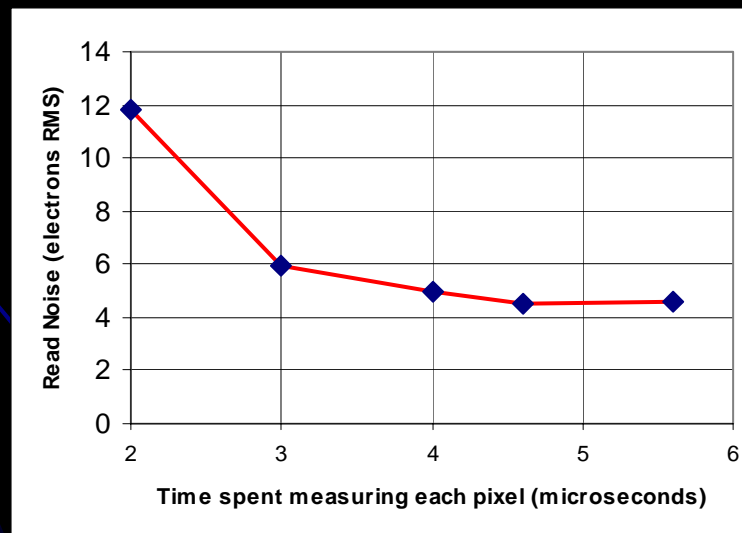

Noise Sources in a CCD Image 5.

DARK CURRENT.

Electrons can be generated in a pixel either by thermal motion of the silicon atoms or by the absorption of photons. Electrons produced by these two effects are indistinguishable. Dark current is analogous to the fogging that can occur with photographic emulsion if the camera leaks light. Dark current can be reduced or eliminated entirely by cooling the CCD. Science cameras are typically cooled with liquid nitrogen to the point where the dark current falls to below 1 electron per pixel per hour where it is essentially un-measurable. Amateur cameras cooled thermoelectrically may still have substantial dark current. The graph below shows how the dark current of a TEK1024 CCD can be reduced by cooling.

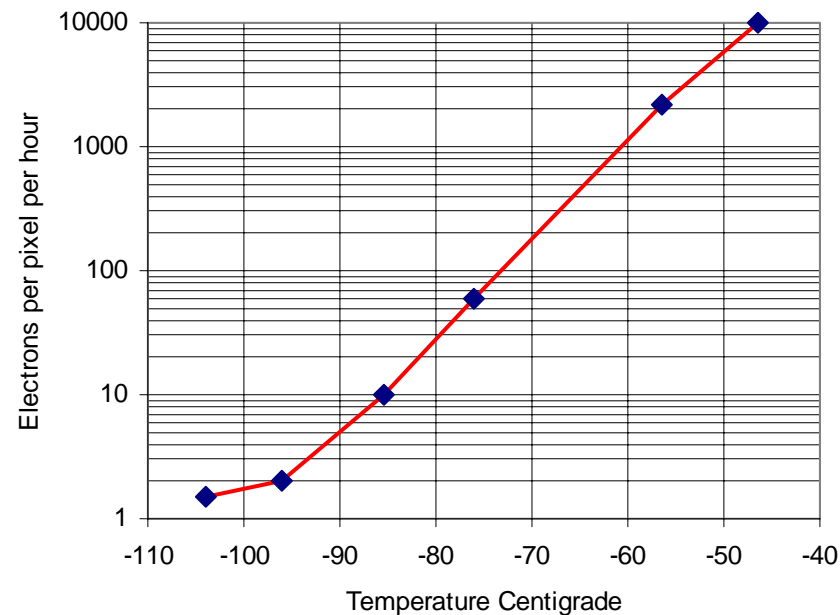

Noise Sources in a CCD Image 6.

PHOTON NOISE.

This can be understood more easily if we go back to the analogy of rain drops falling onto an array of buckets; the buckets being pixels and the rain drops photons. Both rain drops and photons arrive discretely, independently and randomly and are described by Poissonian statistics. If the buckets are very small and the rain fall is very sparse, some buckets may collect one or two drops, others may collect none at all. If we let the rain fall long enough all the buckets will measure the same value, but for short measurement times the spread in measured values is large. This latter scenario is essentially that of CCD astronomy where small pixels are collecting very low fluxes of photons.

Poissonian statistics tells us that the Root Mean square uncertainty (RMS noise) in the number of photons per second detected by a pixel is equal to the square root of the mean photon flux (the average number of photons detected per second).

For example, if a star is imaged onto a pixel and it produces on average 10 photo-electrons per second and we observe the star for 1 second, then the uncertainty of our measurement of its brightness will be the square root of 10 i.e. 3.2 electrons. This value is the 'Photon Noise'.

Increasing exposure time to 100 seconds will increase the photon noise to 10 electrons (the square root of 100) but at the same time will increase the 'Signal to Noise ratio' (SNR). In the absence of other noise sources the SNR will increase as the square root of the exposure time. Astronomy is all about maximising the SNR.

{ Dark current, described earlier, is also governed by Poissonian statistics. If the mean dark current contribution to an image is 900 electrons per pixel, the noise introduced into the measurement of any pixels photo-charge would be 30 electrons }

Noise Sources in a CCD Image 7.

PIXEL RESPONSE NON-UNIFORMITY (PRNU).

If we take a very deep (at least 50,000 electrons of photo-generated charge per pixel) flat field exposure, the contribution of photon noise and read noise become very small. If we then plot the pixel values along a row of the image we see a variation in the signal caused by the slight variations in sensitivity between the pixels. The graph below shows the PRNU of an EEV4280 CCD illuminated by blue light. The variations are as much as $\pm 2\%$. Fortunately these variations are constant and are easily removed by dividing a science image, pixel by pixel, by a flat field image.

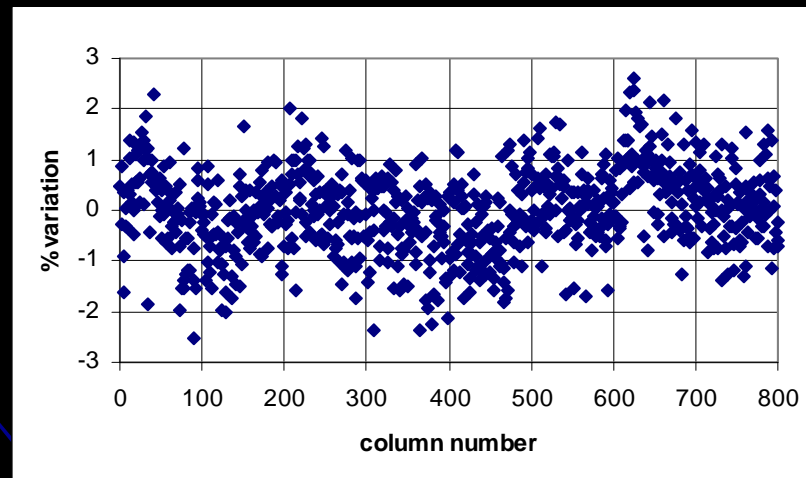

Noise Sources in a CCD Image 8.

HOW THE VARIOUS NOISE SOURCES COMBINE

Assuming that the PRNU has been removed by flat fielding, the three remaining noise sources combine in the following equation:

$$\text{NOISE}_{\text{total}} = \sqrt{(\text{READ NOISE})^2 + (\text{PHOTON NOISE})^2 + (\text{DARK CURRENT})^2}$$

In professional systems the dark current tends to zero and this term of the equation can be ignored. The equation then shows that read noise is only significant in low signal level applications such as Spectroscopy. At higher signal levels, such as those found in direct imaging, the photon noise becomes increasingly dominant and the read noise becomes insignificant. For example, a CCD with read noise of 5 electrons RMS will become photon noise dominated once the signal level exceeds 25 electrons per pixel. If the exposure is continued to a level of 100 electrons per pixel, the read noise contributes only 11% of the total noise.

Photon Transfer Method 1.

The method actually measures the conversion gain of the CCD camera; the number of electrons represented by each digital interval (ADU: Analog to Digital Unit) of the analog to digital converter, however, once the gain is known the read noise follows straightforwardly.

This method exploits the Poissonian statistics of photon arrival. To use it, one requires an image analysis program capable of doing statistical analysis on selected areas of the input images.

Photon Transfer Method 2.

The noise variance can be considered, when correlated noise sources are negligible, as the quadratic sum of 2 terms:

$\sigma_{read(e)}^2$ is the variance of the readout noise (due to detector and analog chain) and

$\sigma_{phot(e)}^2$ is the variance of the photon noise (due to detector and analog chain)

$$\sigma_{(e)}^2 = \sigma_{read(e)}^2 + \sigma_{phot(e)}^2$$

The number of photons is :

$$N = S_{(e)} - S_{bias(e)}$$

Because the photon statistic is Poissonian, photon noise is the square root of the number N of photo-electrons:

$$\sigma_{phot(e)} = \sqrt{N} = \sqrt{S_{(e)} - S_{bias(e)}}$$

Then:

$$\sigma_{(e)}^2 = \sigma_{read(e)}^2 + (S_{(e)} - S_{bias(e)})$$

Where $S_{bias(e)}$ is the “bias signal”: offset of the analog chain in absence of detector signal, i.e. detector signal in the dark (shutter) at short exposure

Photon Transfer Method 3.

Lets define the factor k by : $\sigma_{(adu)} = k.\sigma_{(e)}$

And also: $S_{(adu)} = k.S_{(e)}$

Then :

$$\frac{\sigma_{(adu)}^2}{k^2} = \frac{\sigma_{read(adu)}^2}{k^2} + \frac{(S_{(adu)} - S_{bias(adu)})}{k}$$

Or:

$$\sigma_{(adu)}^2 = \sigma_{read(adu)}^2 + k.(S_{(adu)} - S_{bias(adu)}) = \sigma_{read(adu)}^2 + \frac{(S_{(adu)} - S_{bias(adu)})}{gain}$$

Where: gain= 1/k = system gain in (e/adu)

Then if we plot the signal variance (in adu) as a function of the mean signal (minus the bias), one should find a linear curve from which the slope is the inverse of the system gain and the intersection with the Y axis the readout noise variance:

Photon Transfer Method 4.

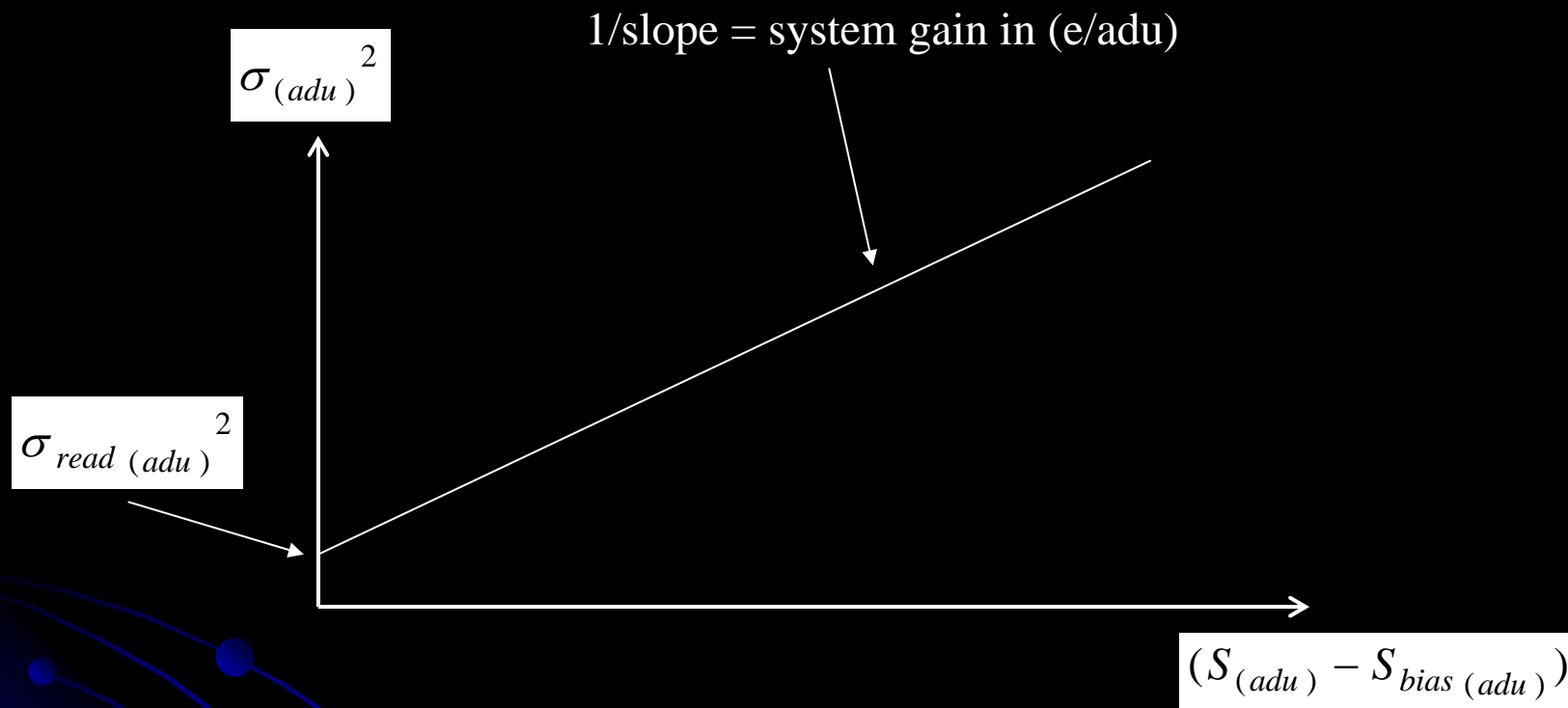

- Store several cubes of ~100 images at various signal levels, up to 1/3 of detector saturation (= Full Well)
- On selected areas where the signal is homogenous and without defect, compute mean signal and signal variance in adu.
- Plot the previous curve, do linear fit
- Extract system gain (in e/adu) by computing the inverse of the slope 1/k
- Calculate also readout noise (if square root is not negative!)

Noise measurements

In case previous method fails, one can also compute noise from a cube of images taken in the dark:

- Store a cube of ~100 images of the CCD in the dark
- Compute the temporal variance of the cube in adu
- Select clean area of CCD (without defect) and calculate the mean variance in adu over the selected pixel, that is called $\sigma_{\text{dark(adu)}}^2$
- The RMS (Root Mean Square) readout noise in adu is the square root of the temporal variance:

$$RMS_{(adu)} = \sqrt{\sigma_{\text{dark(adu)}}^2}$$

- Then we can also compute the RMS noise in electron (e) of the CCD, which is an extremely important characteristics of the camera system (detector + electronics). We just have to multiply the RMS noise in adu by the system gain in e/adu:

$$RMS_{(e)} = \text{gain} \cdot RMS_{(adu)}$$

Deep Depletion CCDs 1.

The electric field structure in a CCD defines to a large degree its Quantum Efficiency (QE). Consider first a thick frontside illuminated CCD, which has a poor QE.

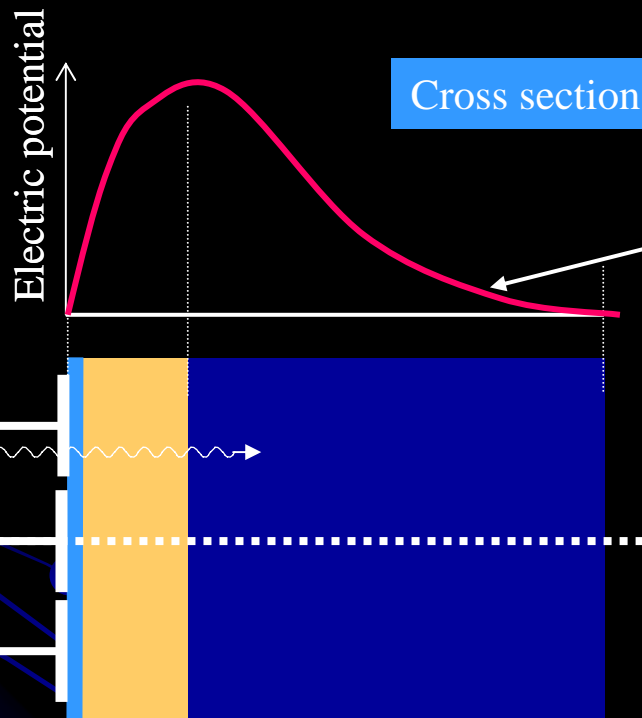

Cross section through a thick frontside illuminated CCD

In this region the electric potential gradient is fairly low i.e. the electric field is low.

Potential along this line shown in graph above.

Any photo-electrons created in the region of low electric field stand a much higher chance of recombination and loss. There is only a weak external field to sweep apart the photo-electron and the hole it leaves behind.

Deep Depletion CCDs 2.

In a thinned CCD, the field free region is simply etched away.

Electric potential

Cross section through a thinned CCD

There is now a high electric field throughout the full depth of the CCD.

This volume is etched away during manufacture

Red photons can now pass right through the CCD.

Problem : Thinned CCDs may have good blue response but they become transparent at longer wavelengths; the red response suffers.

Photo-electrons created anywhere throughout the depth of the device will now be detected. Thinning is normally essential with backside illuminated CCDs if good blue response is required. Most blue photo-electrons are created within a few nanometers of the surface and if this region is field free, there will be no blue response.

Deep Depletion CCDs 3.

Ideally we require all the benefits of a thinned CCD plus an improved red response. The solution is to use a CCD with an intermediate thickness of about $40\mu\text{m}$ constructed from Hi-Resistivity silicon. The increased thickness makes the device opaque to red photons. The use of Hi-Resistivity silicon means that there are no field free regions despite the greater thickness.

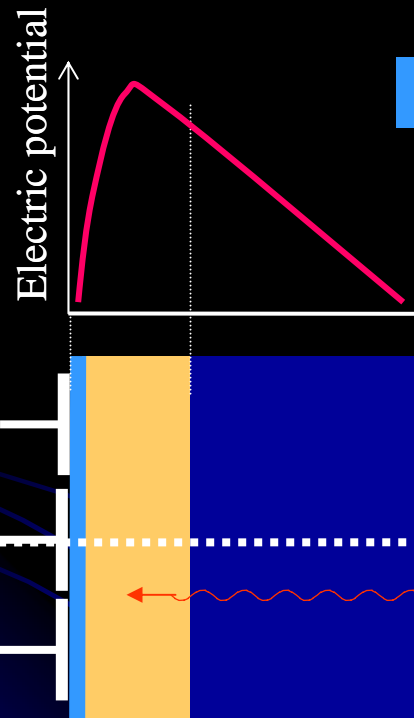

Cross section through a Deep Depletion CCD

Problem :

Hi resistivity silicon contains much lower impurity levels than normal. Very few wafer fabrication factories commonly use this material and deep depletion CCDs have to be designed and made to order.

Red photons are now absorbed in the thicker bulk of the device.

There is now a high electric field throughout the full depth of the CCD. CCDs manufactured in this way are known as Deep depletion CCDs. The name implies that the region of high electric field, also known as the 'depletion zone' extends deeply into the device.

Deep Depletion CCDs 4.

The graph below shows the improved QE response available from a deep depletion CCD.

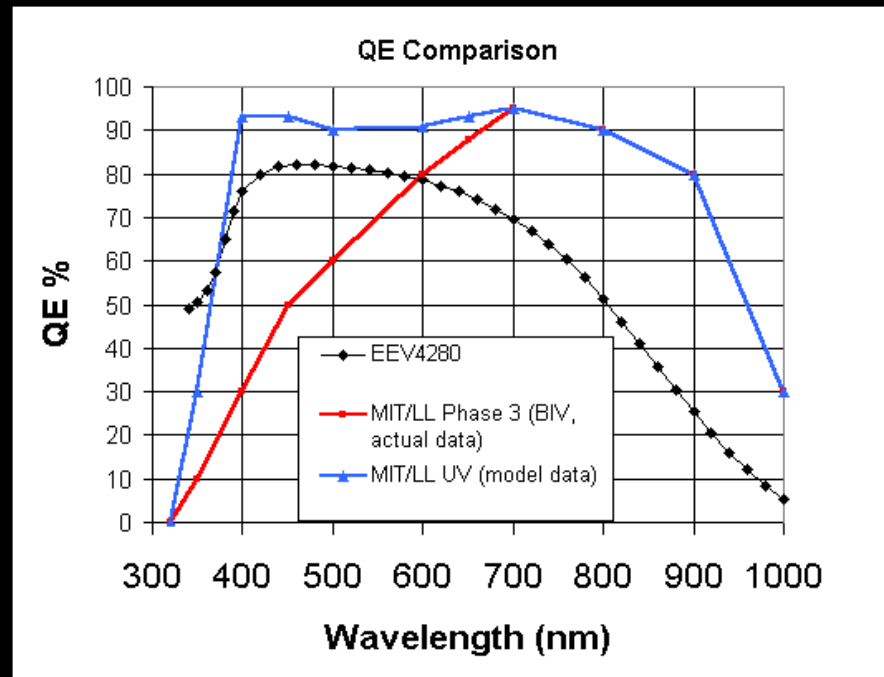

The black curve represents a normal thinned backside illuminated CCD. The Red curve is actual data from a deep depletion chip manufactured by MIT Lincoln Labs. This latter chip is still under development. The blue curve suggests what QE improvements could eventually be realised in the blue end of the spectrum once the process has been perfected.

Deep Depletion CCDs 5.

Another problem commonly encountered with thinned CCDs is 'fringing'. This is greatly reduced in deep depletion CCDs. Fringing is caused by multiple reflections inside the CCD. At longer wavelengths, where thinned chips start to become transparent, light can penetrate through and be reflected from the rear surface. It then interferes with light entering for the first time. This can give rise to constructive and destructive interference and a series of fringes where there are minor differences in the chip thickness.

The image below shows some fringes from an EEV42-80 thinned CCD

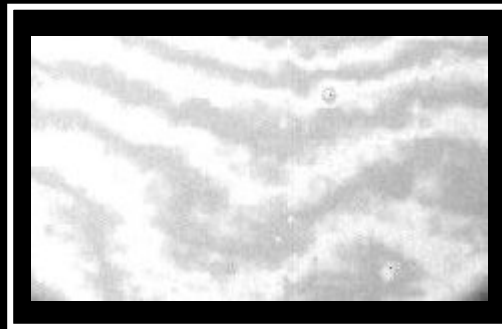

For spectroscopic applications, fringing can render some thinned CCDs unusable, even those that have quite respectable QEs in the red. Thicker deep depletion CCDs, which have a much lower degree of internal reflection and much lower fringing are preferred by astronomers for spectroscopy.

Chapter 4

Low Light Level CCDs (LLLCCD)

A new idea from Marconi (E2V technologies) to reduce or eliminate CCD read-out noise.

LLLCCD = L3CCD = Low Light Level CCD

Also known as EMCCD = Electron Multiplying CCD

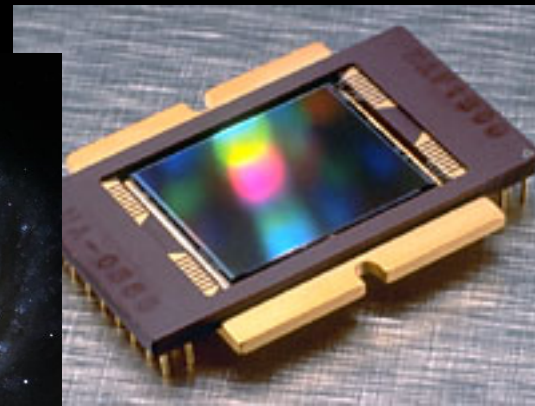
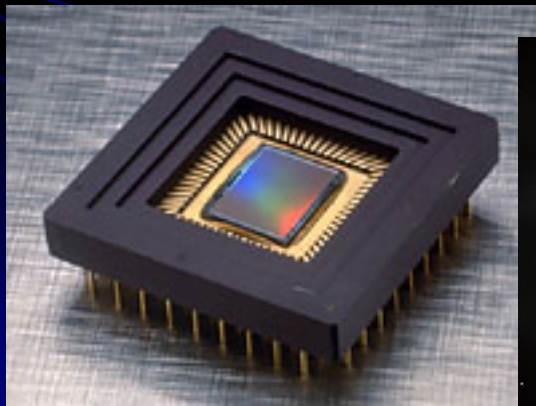

Photomicrograph of a corner of an EEV CCD.

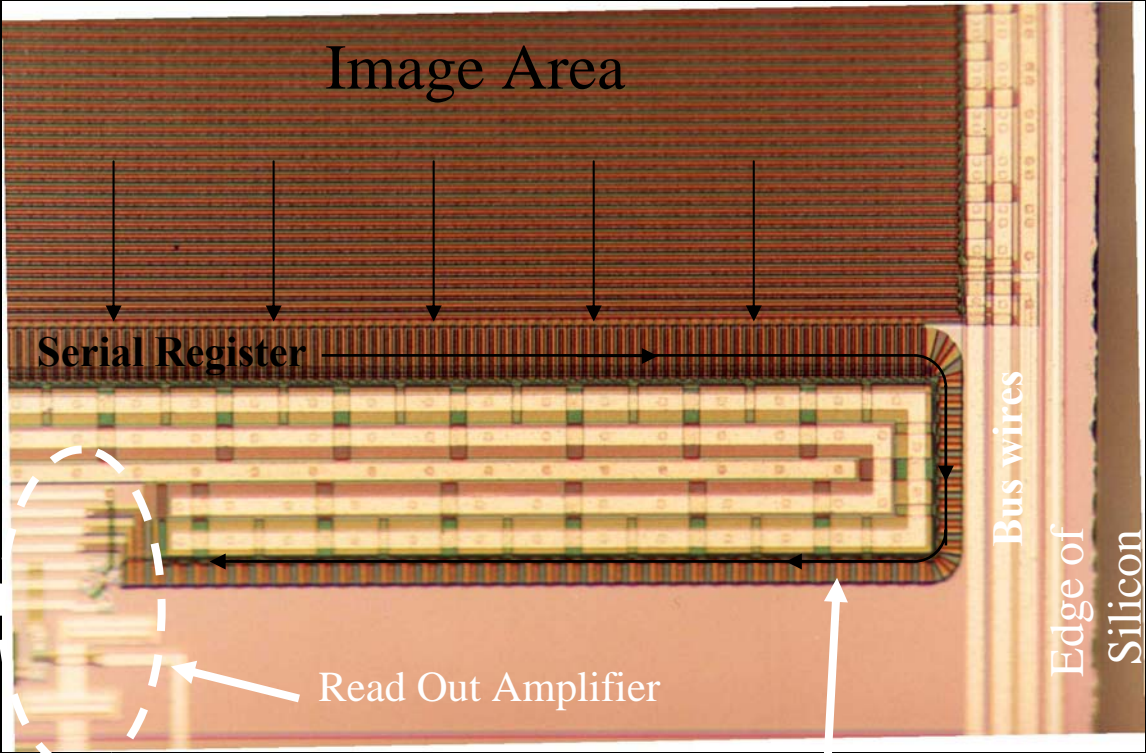

Multiplication register has been added

LLLCCD Gain Register Architecture

Conventional CCD

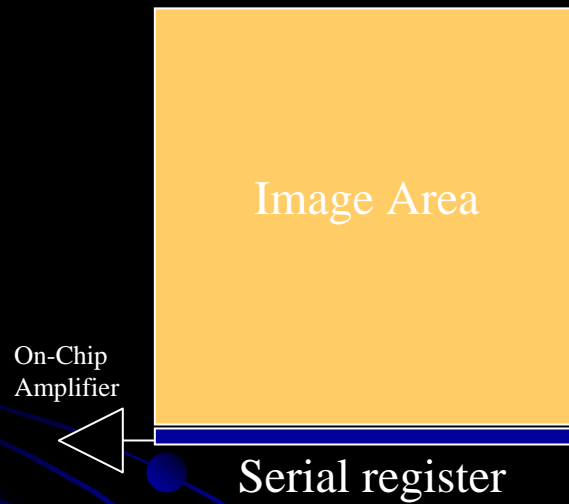

LLLCCD

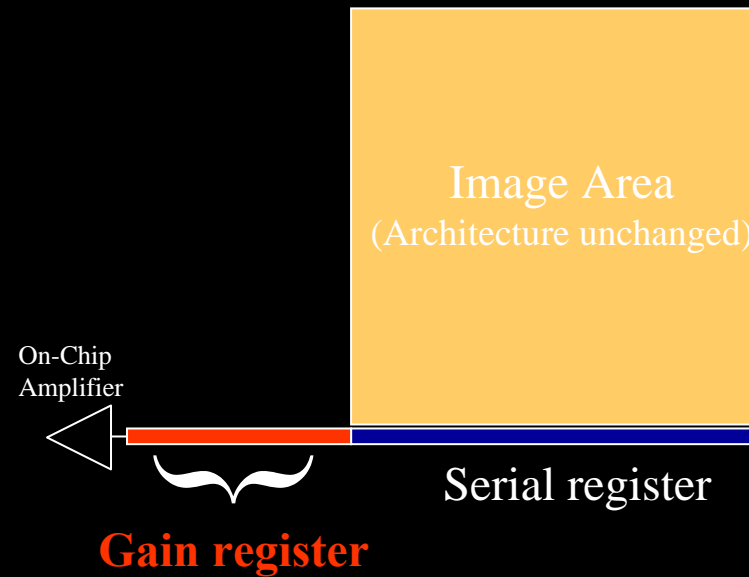

The Gain Register can be added to any existing design

Multiplication Clcking 1

In this diagram we see a small section of the gain register

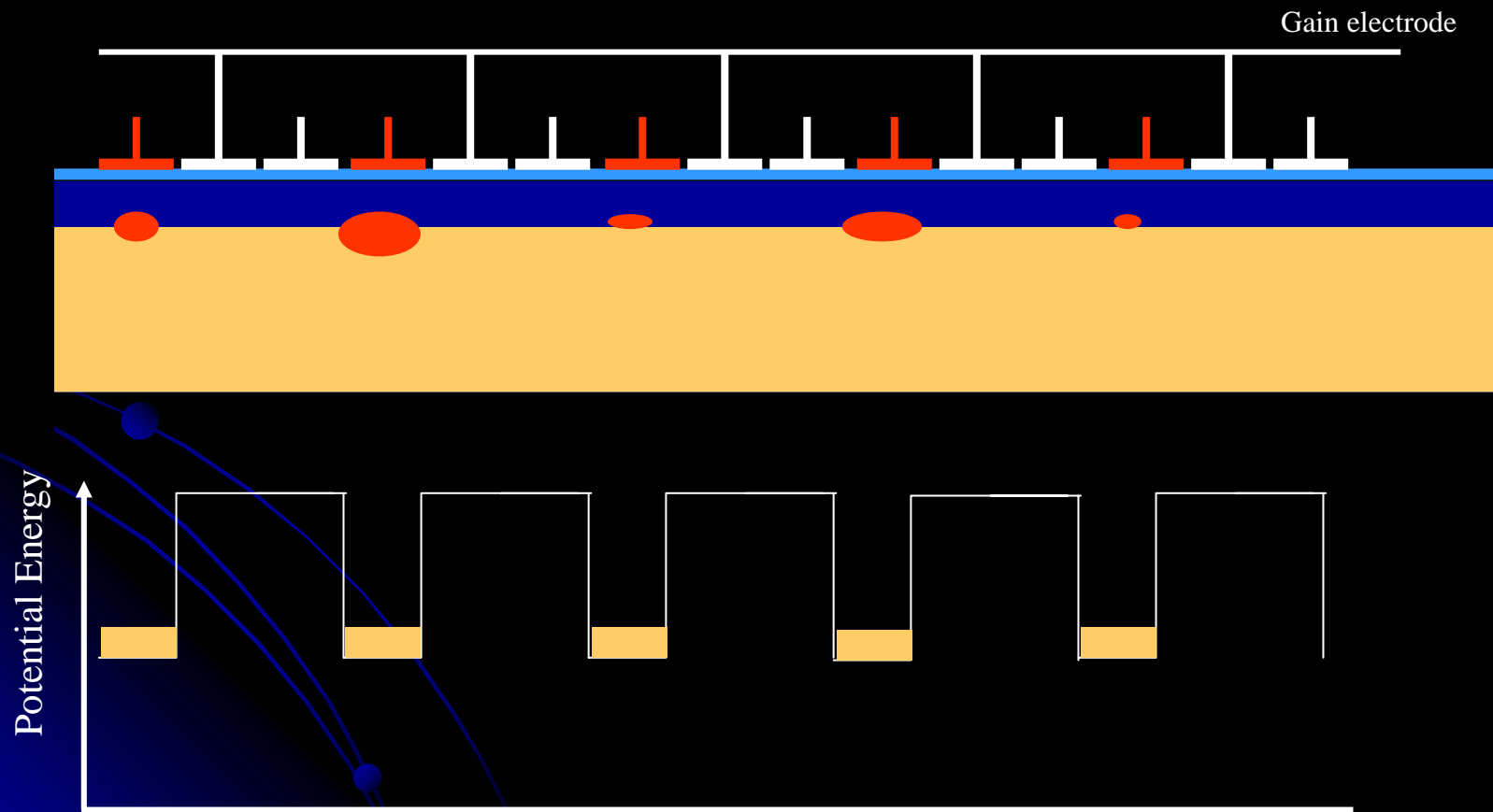

Multiplication Clcking 2

Gain electrode energised. Charge packets accelerated strongly into deep potential well because one phase/pixel has a bigger voltage swing.

Energetic electrons loose energy through creation of more charge carriers (analogous to multiplication effects in the dynodes of a photo-multiplier) .

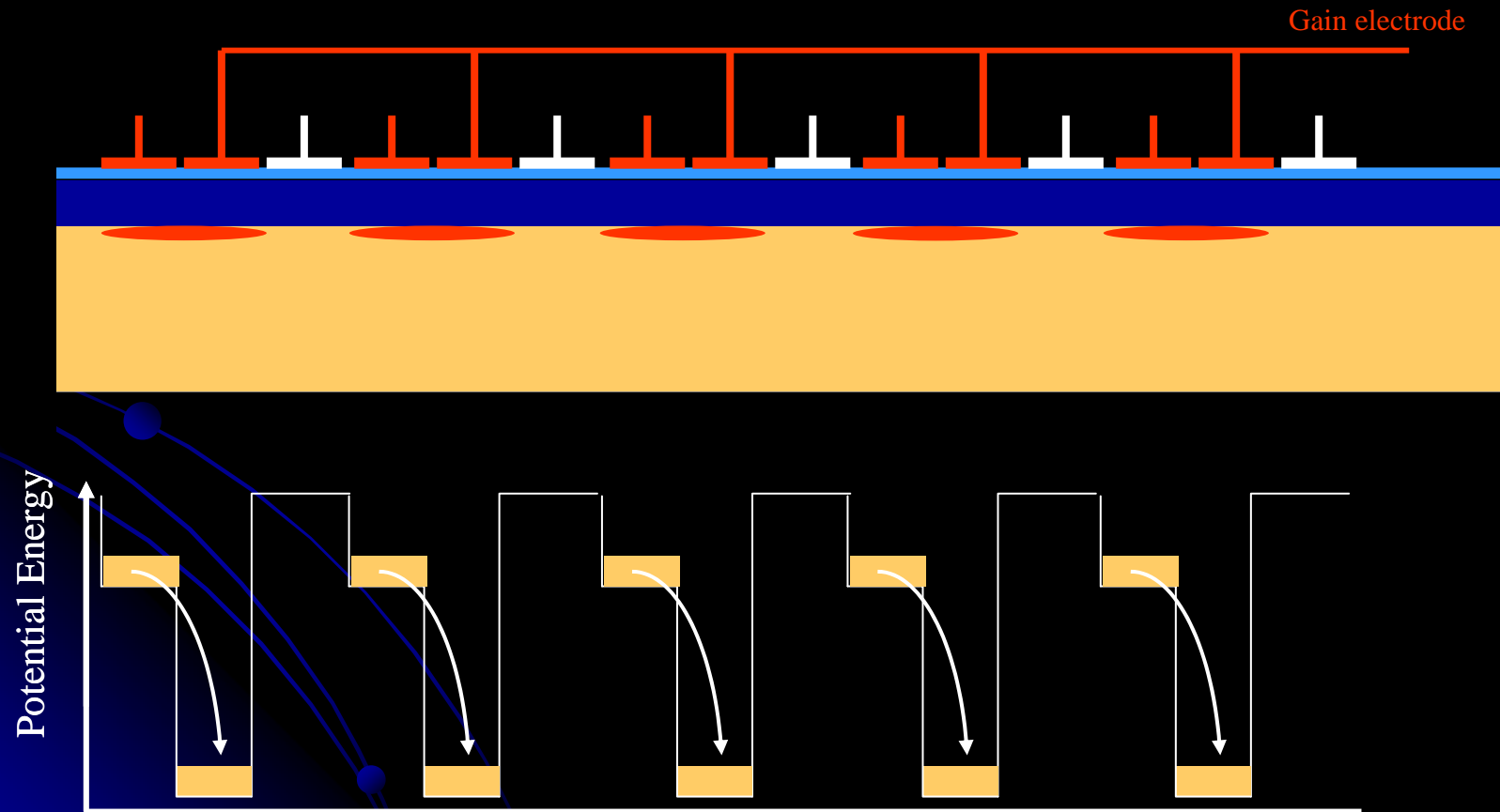

Multiplication Clcking 3

Clocking continues but each time the charge packets pass through the gain electrode, further amplification is produced. Gain per stage is low, <1.015 , however the number of stages is high so the total gain can easily exceed 10,000

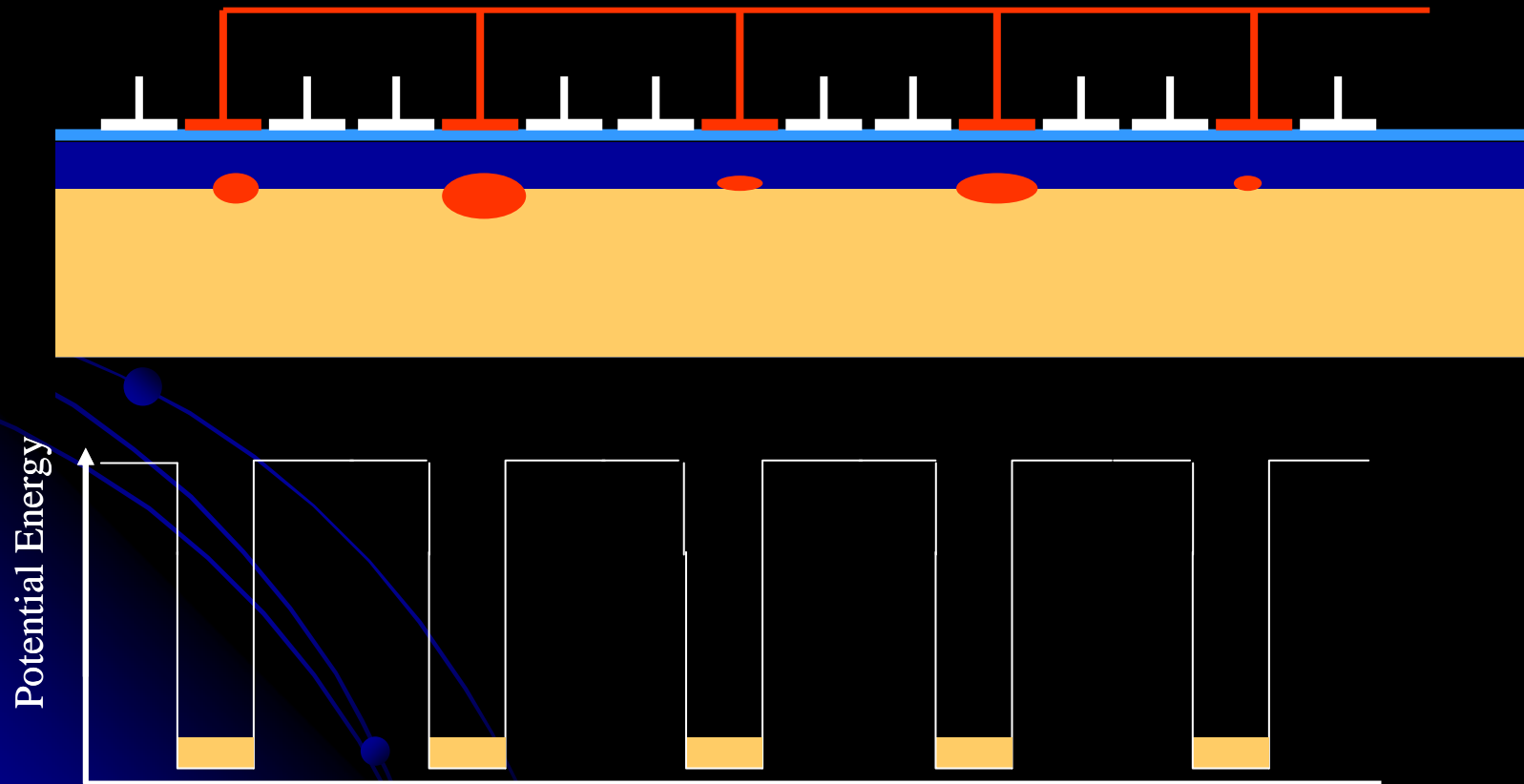

Multiplication Clcking 4

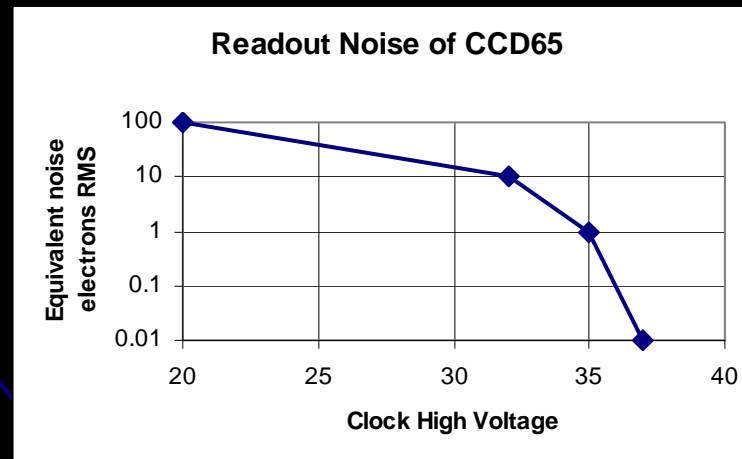
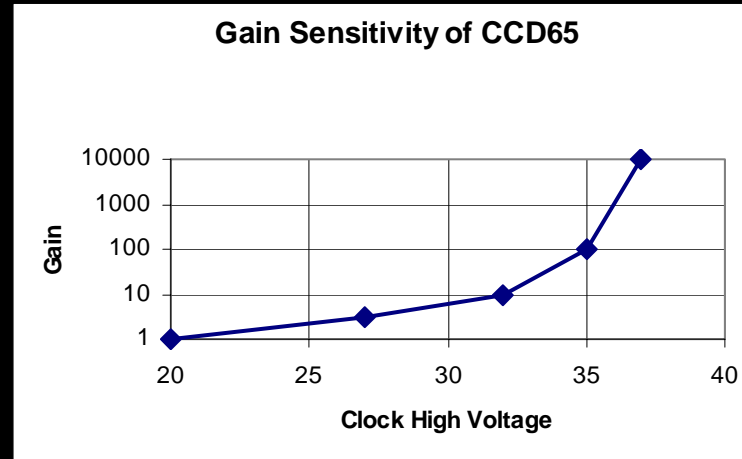

The Multiplication Register has a gain strongly dependant on the clock voltage

Noise Equations 1.

Conventional CCD SNR Equation

$$\text{SNR} = Q \cdot I \cdot t \cdot [Q \cdot t \cdot (I + B_{\text{SKY}}) + N_r^2]^{-0.5}$$

Q = Quantum Efficiency

I = Photons per pixel per second

t = Integration time in seconds

B_{SKY} = Sky background in photons per pixel per second

N_r = Amplifier (read-out) noise in electrons RMS

Very hard to get $N_r < 3e$, and then only by slowing down the readout significantly. At TV frame rates, noise $> 50e$

Trade-off between readout speed and readout noise

Noise Equations 2.

LLLCCD SNR Equation

$$\text{SNR} = Q \cdot I \cdot t \cdot F_n \cdot [Q \cdot t \cdot F_n \cdot (I + B_{\text{SKY}}) + (N_r/G)^2]^{-0.5}$$

G = Gain of the Gain Register

F_n = Multiplication Noise factor = 0.5

With G set sufficiently high,
this term goes to zero, even at
TV frame rates.

Unfortunately, the problem of multiplication noise is introduced

Readout speed and readout noise are decoupled

Multiplication Noise (or excess noise) 1.

In this example, A flat field image is read out through the multiplication register.
Mean illumination is 16e/pixel. Multiplication register gain =100

- Ideal Histogram, $\text{StdDev} = \text{Gain} \times (\text{Mean Illumination in electrons})^{0.5}$
- Actual Histogram, $\text{StdDev} = \text{Gain} \times (\text{Mean Illumination in electrons})^{0.5} \times M$

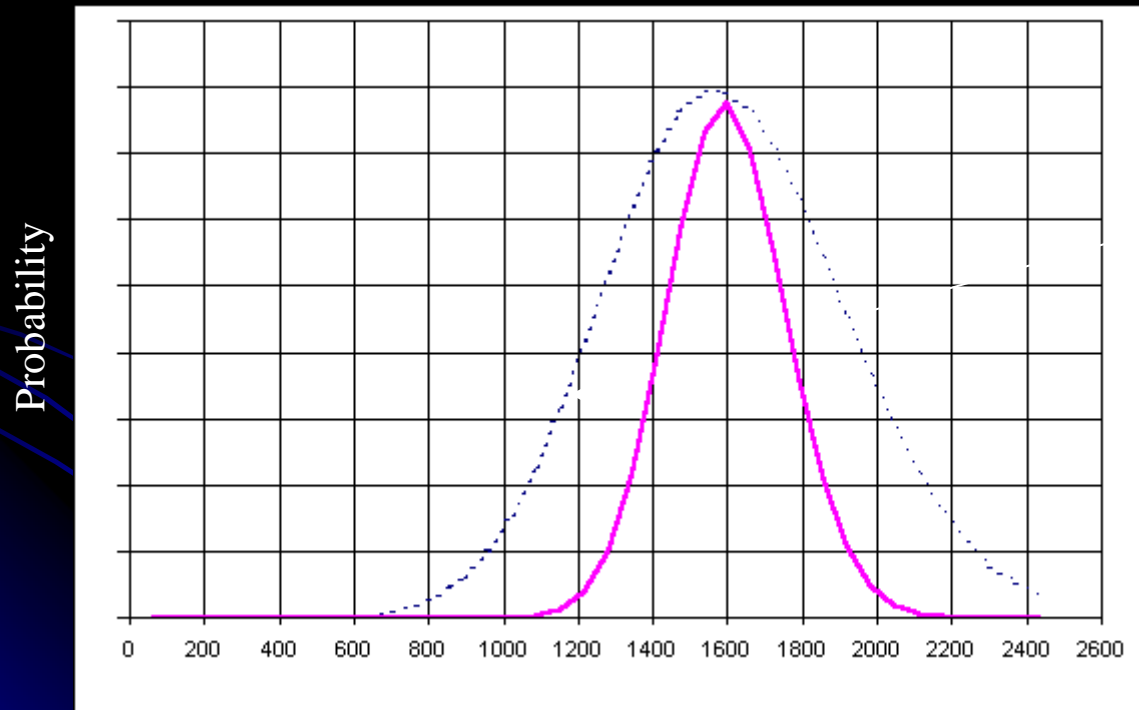

Histogram broadened
by multiplication noise

$$M \approx 1.4 \approx \sqrt{2}$$

Electrons per pixel at output of multiplication register

Multiplication Noise 2.

In high signal environments, LLLCCDs will generally perform *worse* than conventional CCDs. They come into their own, however, in low signal, high-speed regimes.

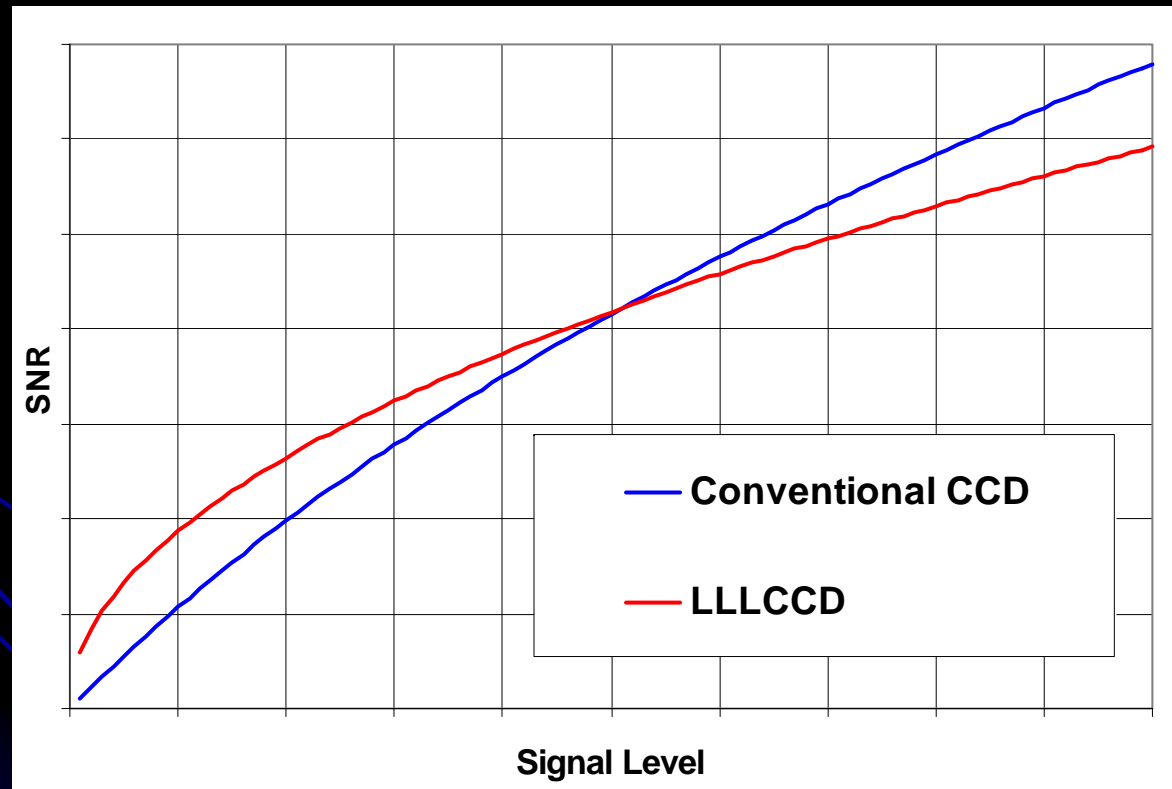

Summary.

The three operational regimes of LLLCCDs

1) Unity Gain Mode.

The CCD operates normally with the SNR dictated by the photon shot noise added in quadrature with the amplifier read noise. In general a slow readout is required (300KPix/second) to obtain low read noise (4 electrons would be typical). Higher readout speeds possible but there will be a trade-off with the read-noise.

2) High Gain Mode.

Gain set sufficiently high to make noise in the readout amplifier of the CCD negligible. The drawback is the introduction of Multiplication Noise that reduces the SNR by a factor of 1.4. Read noise is de-coupled from read-out speed. Very high speed readout possible, up to 11MPixels per second, although in practice the frame rate will probably be limited by factors external to the CCD.

3) Photon Counting Mode.

Gain is again set high but the video waveform is passed through a comparator. Each trigger of the comparator is then treated as a single photo-electron of equal weight. Multiplication noise is thus eliminated. Risk of coincidence losses at higher illumination levels.



Custom L3Vision CCD for Adaptive Optics Applications

**Mark Downing, Robin Arsenault, Dietrich Baade, Norbert Hubin,
Markus Kasper, Manfred Meyer, Javier Reyes.**

European Southern Observatory ESO (<http://www.eso.org>)

**Ray Bell, David Burt, Sandy Denney, Paul Jorden, Peter Pool, Michael
Skegg, Wolfgang Suske, Pat Wheeler.**

e2v technologies ltd (<http://e2vtechnologies.com>)

Philippe Feautrier, Eric Stadler, Yves Magnard.

Domaine Universitaire LOAG (<http://www-laog.obs.ujf-grenoble.fr/JRA2>)

Jean-Luc Gach, Philippe Balard.

Laboratoire d'Astrophysique de Marseille LAM (<http://www.lam.oamp.fr>)

Christian Guillaume.

Observatoire de Haute Provence OHP (<http://www.obs-hp.fr>)

José Javier Diaz Garcia.

IAC, Institute of Astrophysics Canary Islands (<http://www.iac.es>)

Thierry Fusco.

ONERA (<http://www.onera.fr>)

Major Performance Driver

VLT SPHERE (PF)

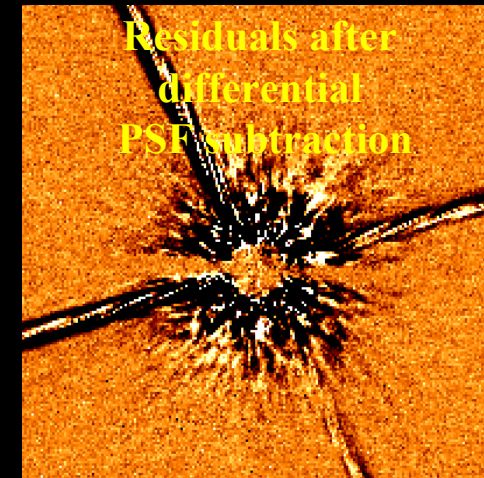
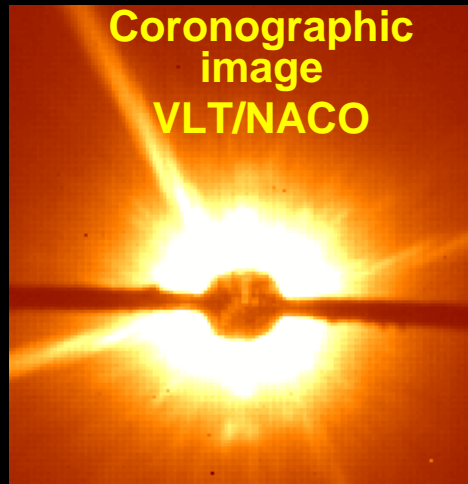

- SPHERE (Planet Finder) needs to detect faint planets close to very bright stars with luminosity contrast ratios $> 10^5$.
- This is only achievable by ultra accurate differential measurements requiring excellent image quality and stability from its AO system.
- The WFS Detector has been identified as a critical component of this AO system and its performance is paramount not only to the success of SPHERE but other 2nd Generation VLT instruments like MUSE and HAWK-I.

Requirements

Present Systems

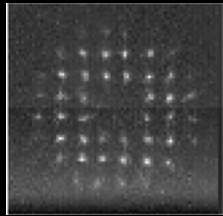

14x14
SH-WFS

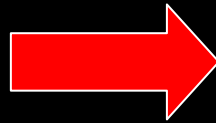

Next Generation Systems

40x40 SH-WFS
(mag~10, RON=1e-)

240x240 pixels

Each
Sub-aperture
6x6 pixels

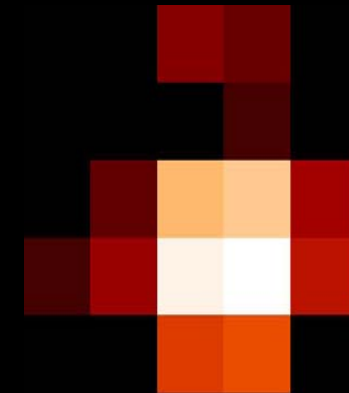

1. 40x40 SH subapertures x 6x6 pixels/sub-aperture \Rightarrow 240x240 pixels.
2. Versatility: 100% fill factor / 240x240 square grid array of pixels that can be used with any type of WFS system; SH, curvature, or pyramid.
3. > 1.2 kHz frame rate to match the increased spatial sampling.

L3CCD with lower read noise wins

White-Yellow GS

Red GS

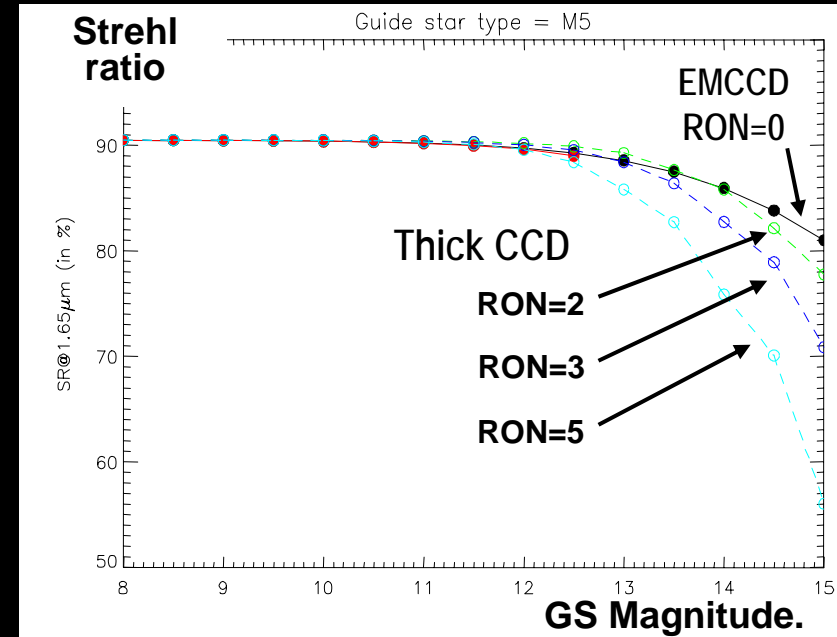
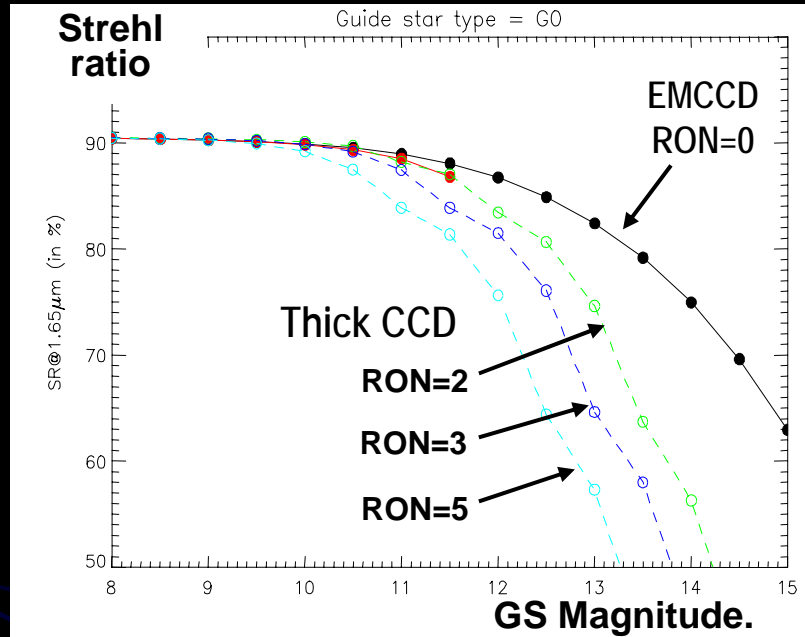

- However, one needs to look at the total picture both QE and RON.
- Low read noise of EMCCD is clearly better for white-yellow guide star
- and better even for red GS if RON of Thick CCD $> 2e$.
- Conclusion low RON ($\sim 0.1e^-$) is better than higher red response.
- Reason e2v-L3Vision was chosen.

The e2v CCD 220 Design

Store slanted to allow room for multiple outputs.

Metal Buttressed 2Φ 10 Mhz Clocks for fast image to store transfer rates.

8 L3Vision Gain Registers/Outputs. Each 15Mpix./s.

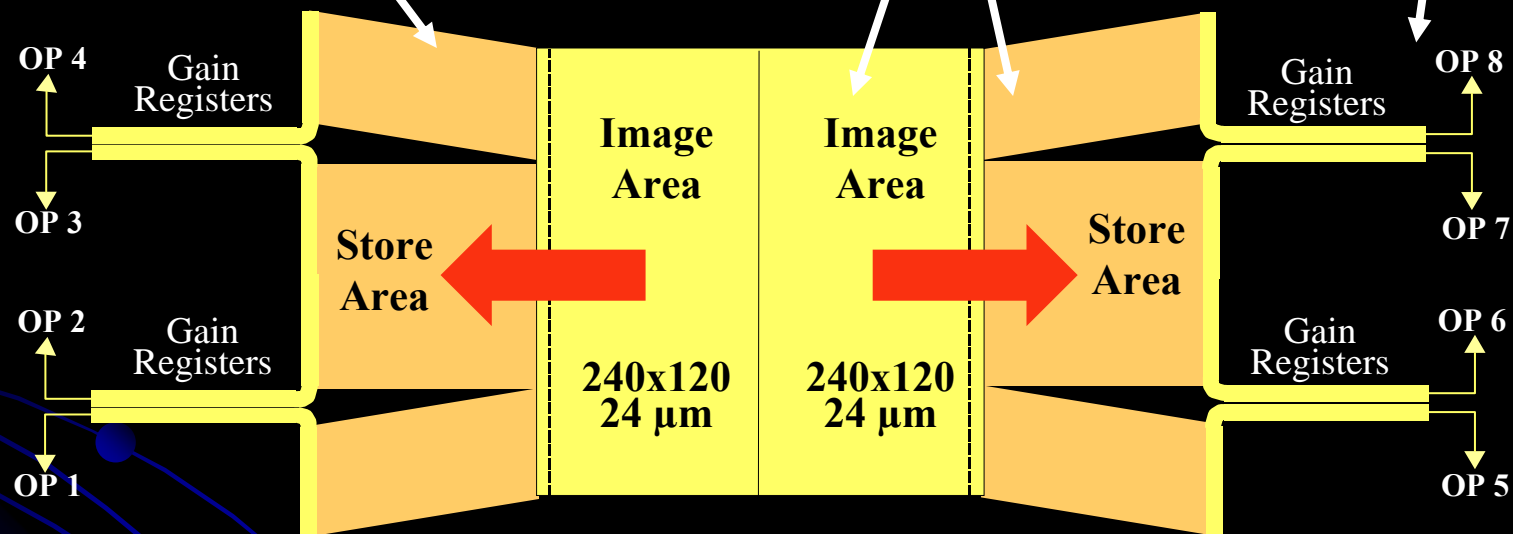

Split frame transfer 8-output back-illuminated e2v-L3Vision CCD.

CCD Package with Peltier coolers

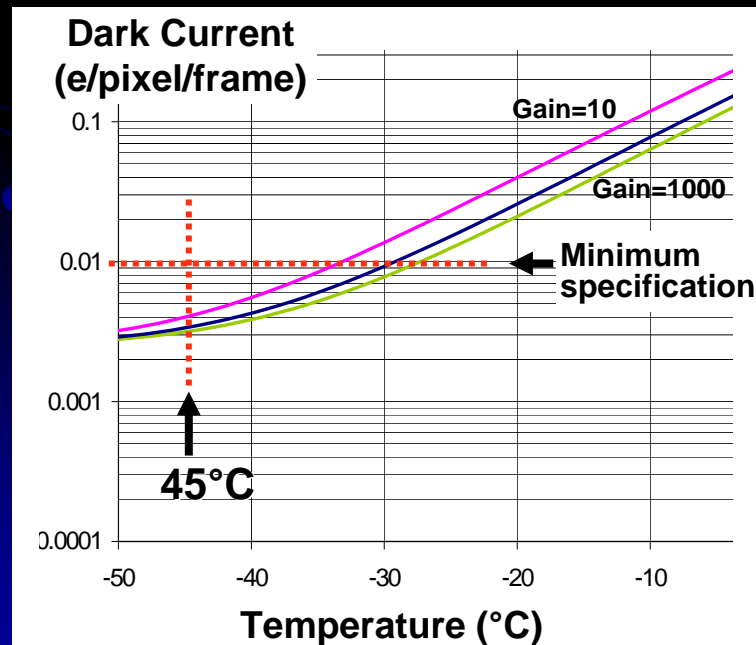
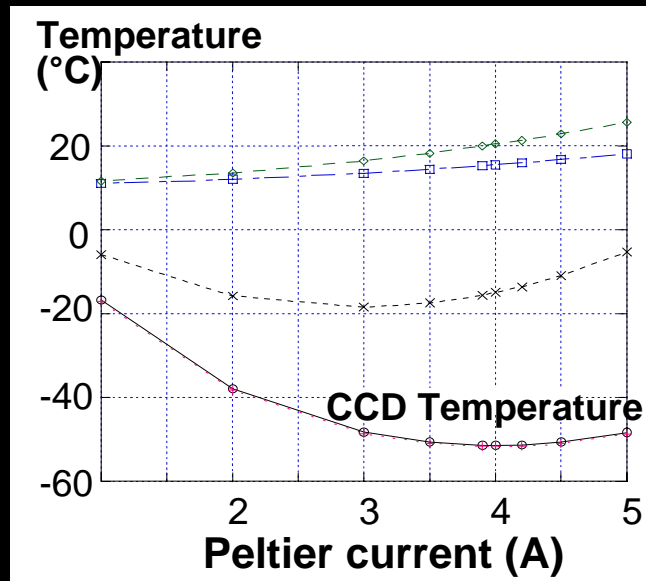

- Integral custom Peltier cooled package.
 - For compactness.
 - Ease of use - minimal support equipment – no LN2, no cryocoolers etc.
- Use of I-deas 11 / TMG to thermally model the package.
- Results shows that the CCD can be cooled in excess of 45 °C.
- Which enables not only minimum dark current of 0.01 e/pixel/frame to be meet but almost the goal of 0.001 e/pixel/frame.

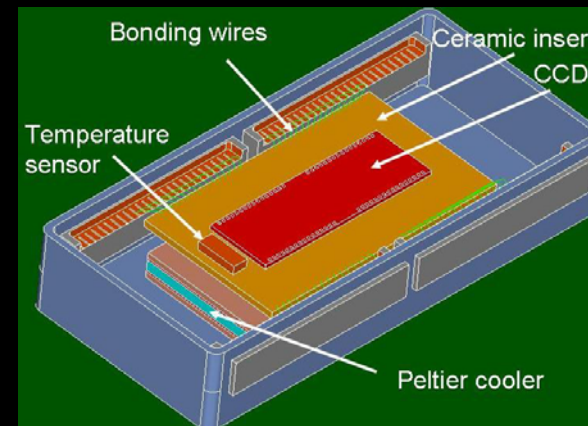

END
Many Thanks for
Listening